



# Extra Small 30 Metric Series

Extra small, 30 Metric Series ball bearings can sustain radial, thrust and combined loads proportionate to the capacities of the small shafts for which they are designed. They are especially suitable for use in fractional horsepower motors, domestic appliances, precision instruments, tape recorders and similar devices. In addition to the basic bearing, this series offers various combinations of shields and seals as listed below.

These bearings are electric motor quality for applications where extra quietness is a requirement.

Some sizes in this series are available in stainless steel. When ordering, these are denoted by a prefix A before the bearing number. Example: A38K.

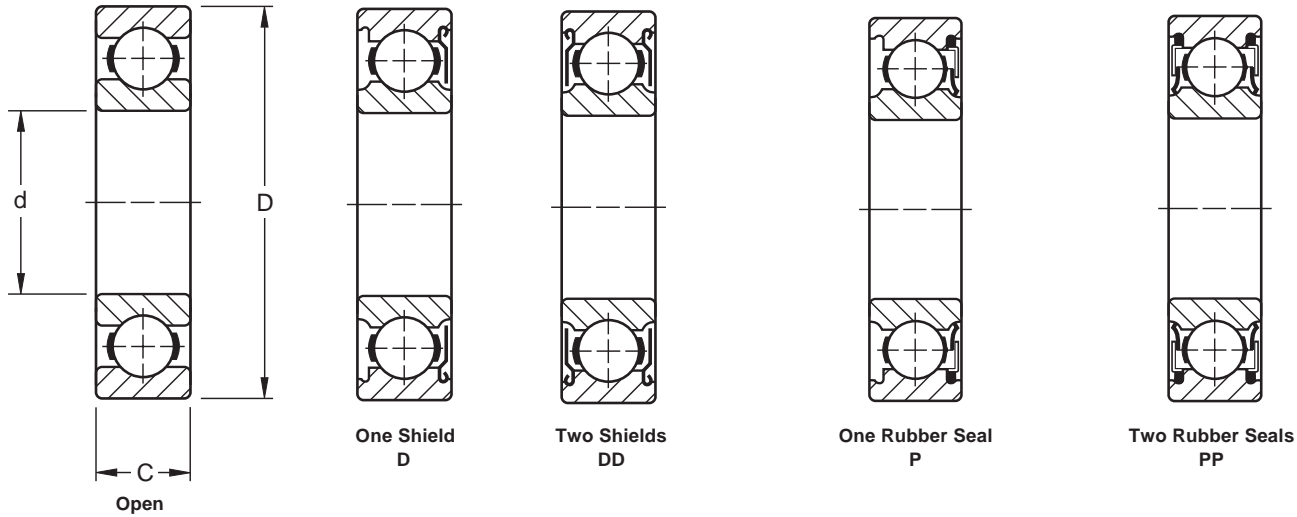

## OPEN AND SHIELDED TYPES DIMENSIONS – TOLERANCES

open	Bearing Number		Bore d		Outside Diameter D				Width C		Fillet Radius <sup>(1)</sup>		Wt		Static Load Rating C <sub>0</sub>		Extended Dynamic Load Rating C <sub>E</sub>	
	one shield D	two shield DD	+0.0000*, -0.0003* +0.000 mm, -0.008 mm		tolerance +0.0000* +0.000 mm to minus				+0.000*, -0.005* +0.00mm, -12mm									
			in.	mm	in.	mm	in.	mm	in.	mm	in.	mm	lbs.	kg.	lbs.	N	lbs.	N
34K	34KD	34KDD	0.1575	4	0.6299	16	0.0003	0.008	0.197	5	0.012	0.3	0.01	0.005	125	560	365	1630
35K	35KD	35KDD	0.1969	5	0.7480	19	0.00035	0.009	0.236	6	0.012	0.3	0.02	0.009	195	865	560	2450
36K	36KD	36KDD	0.2362	6	0.7480	19	0.00035	0.009	0.236	6	0.012	0.3	0.02	0.009	195	865	560	2450
37K	37KD	37KDD	0.2756	7	0.8661	22	0.00035	0.009	0.276	7	0.012	0.3	0.02	0.009	312	1400	830	3650
38K	38KD	38KDD	0.3150	8	0.8661	22	0.00035	0.009	0.276	7	0.012	0.3	0.02	0.009	312	1400	830	3650
38KV	—	—	0.3150	8	0.9449	24	0.00035	0.009	0.276	7	0.012	0.3	0.04	0.018	305	1370	830	3650
39K	39KD	39KDD	0.3543	9	1.0236	26	0.00035	0.009	0.315	8	0.012	0.3	0.04	0.018	440	1960	1120	5000

<sup>(1)</sup> Maximum shaft or housing fillet radius which bearing corners will clear.

## SEALED TYPES DIMENSIONS – TOLERANCES

Bearing Number		Bore d		Outside Diameter D		Width C		Fillet Radius <sup>(1)</sup>		Wt.		Static Load Rating C <sub>0</sub>		Extended Dynamic Load Rating C <sub>E</sub>	
one seal P	two seals PP	+0.0000*, -0.0003* +0.000 mm, -0.008 mm		+0.0000*, -0.00035* +0.000 mm, -0.009 mm		+0.000*, -0.005* +0.00 mm, -12 mm									
		in.	mm	in.	mm	in.	mm	in.	mm	lbs.	kg.	lbs.	N	lbs.	N
36P	36PP	0.2362	6	0.7480	19	0.394	10	0.012	0.3	0.03	0.014	195	865	560	2450
36P2	36PP2	0.2362	6	0.7480	19	0.236	6	0.012	0.3	0.03	0.014	195	865	560	2450
37P	37PP	0.2756	7	0.8661	22	0.394	10	0.012	0.3	0.04	0.018	305	1370	830	3650
37P2	37PP2	0.2756	7	0.8661	22	0.276	7	0.012	0.3	0.04	0.018	312	1400	830	3650
38P	38PP	0.3150	8	0.8661	22	0.394	10	0.012	0.3	0.04	0.018	305	1370	830	3650
38P2	38PP2	0.3150	8	0.8661	22	0.276	7	0.012	0.3	0.04	0.018	312	1400	830	3650
39P	39PP	0.3543	9	1.0236	26	0.315	8	0.024	0.6	0.05	0.023	440	1960	1120	5000

<sup>(1)</sup> Maximum shaft or housing fillet radius which bearing corners will clear.



# Extra Small 30 Metric Series

## MECHANI-SEALS

Fafnir developed Mechani-Seals have been adapted to the 30 metric series for effective grease retention and exclusion of foreign matter. They are available with one Mechani-Seal (suffix L), with one Mechani-Seal and one shield (suffix LD), and with two Mechani-Seals (suffix LL).

Because the Mechani-Seal is frictionless, the bearings can be operated at speeds comparable to those at which the open type bearings can run.

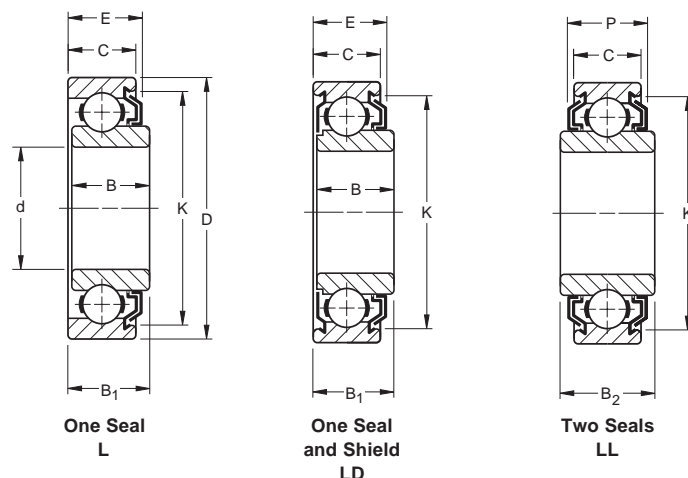

## DIMENSIONS – TOLERANCES

Bearing Number			Bore d		Outside Diameter D		Width			Ring Width +0.000* -0.005* +0.00 mm, -0.12 mm				Fillet Radius <sup>(1)</sup>		Seal Protection				Inner Ring Offset <sup>(2)</sup>		Wt		Static Load Rating C <sub>0</sub>		Extended Dynamic Load Rating C <sub>E</sub>				
one seal L	one seal and shield LD	two seals LL	+0.0000* -0.0003* +0.000 mm -0.008 mm		+0.0000* -0.00035* +0.000 mm -0.009 mm		B <sub>1</sub>			inner B		outer C		in. mm		width E		P		O.D. K		in. mm		lbs. kg		lbs. N		lbs. N		
			in.	mm	in.	mm	in.	mm	in.	mm	in.	mm	in.	mm	in.	mm	in.	mm	in.	mm	in.	mm	in.	mm	lbs.	kg	lbs.	N	lbs.	N
36KL	36KLD	36KLL	0.2362	6	0.7480	19	0.406	10.31	0.386	9.80	0.562	14.27	0.315	8.00	0.012	0.3	0.378	9.60	0.428	10.87	<sup>27</sup> / <sub>64</sub>	16.7	0.020	0.50	0.03	0.014	195	865	560	2450
36KVL	—	—	0.2362	6	0.9449	24	0.406	10.31	0.386	9.80	—	—	0.315	8.00	0.012	0.3	0.378	9.60	—	—	<sup>3</sup> / <sub>4</sub>	19.0	0.020	0.50	0.05	0.022	195	865	560	2450
37KL	37KLD	37KLL	0.2756	7	0.8661	22	0.406	10.31	0.386	9.80	0.562	14.27	0.315	8.00	0.012	0.3	0.378	9.60	0.440	11.18	<sup>47</sup> / <sub>64</sub>	18.7	0.020	0.50	0.04	0.018	312	1400	830	3650
37KVL	37KVDL	—	0.2756	7	0.9449	24	0.406	10.31	0.386	9.80	—	—	0.315	8.00	0.012	0.3	0.378	9.60	—	—	<sup>3</sup> / <sub>4</sub>	19.0	0.020	0.50	0.05	0.022	312	1400	830	3650
38KL	38KLD	38KLL	0.3150	8	0.8661	22	0.406	10.31	0.386	9.80	0.562	14.27	0.315	8.00	0.012	0.3	0.378	9.60	0.440	11.18	<sup>47</sup> / <sub>64</sub>	18.7	0.020	0.50	0.04	0.018	312	1400	830	3650
38KVL	38KVDL	38KVLL	0.3150	8	0.9449	24	0.406	10.31	0.386	9.80	0.562	14.27	0.315	8.00	0.012	0.3	0.378	9.60	0.438	11.13	<sup>3</sup> / <sub>4</sub>	19.0	0.020	0.50	0.05	0.022	305	1370	830	3650
—	—	38KLL2	0.3150	8	0.8661	22	—	—	—	—	0.497	12.62	0.315	8.00	0.012	0.3	—	—	0.440	11.18	<sup>47</sup> / <sub>64</sub>	18.7	—	—	0.05	0.022	305	1370	830	3650
—	—	38KVLL2	0.3150	8	0.9449	24	—	—	—	—	0.497	12.62	0.315	8.00	0.012	0.3	—	—	0.438	11.13	<sup>3</sup> / <sub>4</sub>	19.0	—	—	0.05	0.022	305	1370	830	3650
39KL2	39KLD2	—	0.3543	9	1.0236	26	0.406	10.31	0.386	9.80	—	—	0.315	8.00	0.024	0.6	0.378	9.60	—	—	<sup>27</sup> / <sub>64</sub>	21.4	0.020	0.50	0.05	0.022	440	1960	1120	5000
—	39KVDL	39KVLL2	0.3543	9	1.1811	30	—	—	—	—	0.646	16.41	0.354	9.00	0.024	0.6	—	—	0.629	15.98	1	25.4	0.020	0.50	0.09	0.041	595	2650	1500	6550

<sup>(1)</sup> Maximum shaft or housing fillet radius which bearing corners will clear.

<sup>(2)</sup> Does not apply to bearings with two seals.

Note: Inner ring offset is .020 inches (.51mm) for the L, LD, and VLD versions.

<sup>(3)</sup> Two seals (suffix LL) type only.

## FELT-SEALS

The 30 metric series is available with one felt seal (suffix T), with one felt seal and one shield (suffix TD), and with two felt seals (suffix TT). The felt seal provides an effective barrier against the entrance of foreign matter and the escape of lubricant. It is a contact seal with the felt riding on the ground surface of the inner ring O.D.

Because the felt washer absorbs some lubricant, these bearings can be operated at moderate speeds without excessive heating.

These bearings are electric motor quality for applications where extra quietness is a requirement.

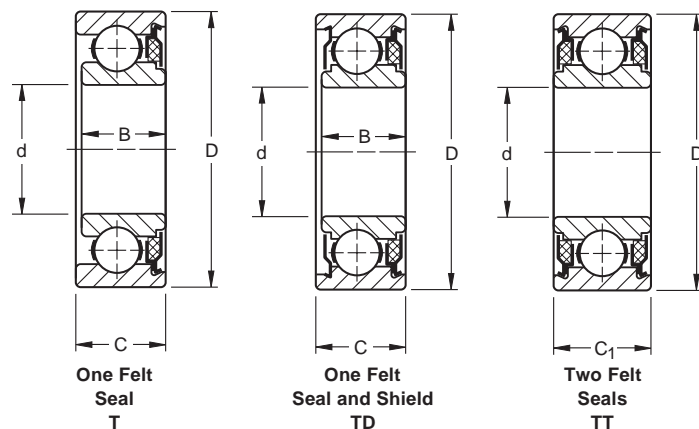

## DIMENSIONS – TOLERANCES

Bearing Number			Bore d		Outside Diameter D		Ring Width +0.000* -0.005* +0.00 mm, -0.12 mm			Inner Ring Offset <sup>(2)</sup>		Fillet Radius <sup>(1)</sup>		Wt		Static Load Rating C <sub>0</sub>		Extended Dynamic Load Rating C <sub>E</sub>				
one seal T	one seal and shield TD	two seals TT	+0.0000* -0.0003* +0.000 mm -0.008 mm		+0.0000* -0.00035* +0.000 mm -0.009 mm		inner B		outer C		C <sub>1</sub>		in. mm		lbs. kg		lbs. N		lbs. N			
			in.	mm	in.	mm	in.	mm	in.	mm	in.	mm	in.	mm	lbs.	kg	lbs.	N	lbs.	N		
36KT	36KTD	36KTT	0.2362	6	0.7480	19	0.386	9.80	0.406	10.31	0.562	14.27	0.020	0.50	0.012	0.3	0.03	0.014	195	865	560	2450
36KVT	36KVTD	—	0.2362	6	0.9449	24	0.386	9.80	0.406	10.31	—	—	0.020	0.50	0.012	0.3	0.06	0.027	305	1370	830	3650
37KT	37KTD	—	0.2756	7	0.8661	22	0.386	9.80	0.406	10.31	—	—	0.020	0.50	0.012	0.3	0.04	0.018	305	1370	830	3650
37KVT	37KVTD	—	0.2756	7	0.9449	24	0.386	9.80	0.406	10.31	—	—	0.020	0.50	0.012	0.3	0.05	0.022	305	1370	830	3650
38KT	38KTD	38KTT	0.3150	8	0.8661	22	0.386	9.80	0.406	10.31	0.562	14.27	0.020	0.50	0.012	0.3	0.04	0.018	305	1370	830	3650
38KVT	38KVTD	38KVTT	0.3150	8	0.9449	24	0.386	9.80	0.406	10.31	0.562	14.27	0.020	0.50	0.012	0.3	0.05	0.022	305	1370	830	3650
39KT	39KTD	39KTT	0.3543	9	1.0236	26	0.437	11.10	0.453	11.51	0.562	14.27	0.016	0.40	0.024	0.6	0.06	0.027	440	1960	1120	5000
39KVT	39KVTD	—	0.3543	9	1.1811	30	0.480	12.19	0.500	12.70	—	—	0.020	0.50	0.024	0.6	0.09	0.041	595	2650	1500	6550

<sup>(1)</sup> Maximum shaft or housing fillet radius which bearing corners will clear.

<sup>(2)</sup> Does not apply to bearings with two seals.



## Extra Small 33 and S Inch Series

Extra Small 33 and S Inch Series bearings can sustain radial, thrust and combined loads proportionate to the capacities of the small shafts for which they are designed. They are especially suitable for use in fractional horsepower motors, domestic appliances, precision instruments, tape recorders and similar devices. The series include various combinations of shields and seals as listed below.

These bearings are electric motor quality for applications where extra quietness is a requirement.

Several sizes in this series are manufactured in both standard bearing quality, chromium-alloy, high carbon steel and stainless steel, as indicated in the tables.

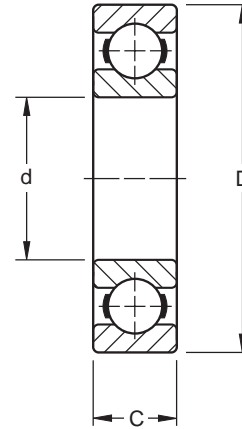

### DIMENSIONS – TOLERANCES

Bearing Number	Bore d				Outside Diameter D				Width C		Fillet Radius <sup>(1)</sup>		Wt		Static Load Rating C <sub>0</sub>		Extended Dynamic Load Rating C <sub>E</sub>		
	tolerance +0.0000* +0.000 mm to minus				tolerance +0.0000* +0.000 mm to minus				+0.000, -0.005* +0.00 mm, -0.13 mm		in. mm		lbs. kg.		lbs. N		lbs. N		
standard stainless	in.	mm	in.	mm	in.	mm	in.	mm	in.	mm	in.	mm	lbs.	kg.	lbs.	N	lbs.	N	
33K3	A33K3	0.1250	3.175	0.0003	0.008	0.3750	9.525	0.0004	0.010	0.156	3.96	0.012	0.3	0.01	0.005	48	212	160	710
33K4	A33K4	0.1250	3.175	0.0003	0.008	0.5000	12.700	0.0004	0.010	0.172	4.37	0.012	0.3	0.01	0.005	110	490	325	1430
33K5	A33K5	0.1875	4.762	0.0003	0.008	0.5000	12.700	0.0004	0.010	0.156	3.96	0.012	0.3	0.01	0.005	110	490	325	1430
S1K7	AS1K7	0.2500	6.350	0.0003	0.008	0.6250	15.875	0.0004	0.010	0.196	4.98	0.012	0.3	0.01	0.005	125	560	365	1630
S1K	AS1K	0.2500	6.350	0.0003	0.008	0.7500	19.050	0.0004	0.010	0.219	5.56	0.016	0.4	0.02	0.009	260	1160	695	3100
S3K	AS3K	0.3750	9.525	0.0003	0.008	0.8750	22.225	0.0004	0.010	0.219	5.56	0.016	0.4	0.02	0.009	312	1400	830	3650
S5K	AS5K	0.5000	12.700	0.0003	0.008	1.1250	28.575	0.0004	0.010	0.250	6.35	0.016	0.4	0.04	0.018	500	2240	1270	5600
S7K	AS7K	0.6250	15.875	0.0003	0.008	1.3750	34.925	0.0005	0.013	0.281	7.14	0.031	0.8	0.07	0.032	682	3050	1700	7500
S8K	—	0.7500	19.050	0.0004	0.010	1.6250	41.275	0.0005	0.013	0.312	7.92	0.031	0.8	0.11	0.050	1000	4400	2320	10400
S9K	—	0.8750	22.225	0.0004	0.010	1.8750	47.625	0.0005	0.013	0.375	9.52	0.031	0.8	0.14	0.064	1120	4900	2500	11000
S10K	—	1.0000	25.400	0.0004	0.010	2.0000	50.800	0.0005	0.013	0.375	9.52	0.031	0.8	0.18	0.082	1120	4900	2500	11000
S11K	—	1.1250	28.575	0.0004	0.010	2.1250	53.975	0.0005	0.013	0.375	9.52	0.031	0.8	0.20	0.091	1220	5400	2650	11800
S12K	—	1.2500	31.750	0.0005	0.013	2.2500	57.150	0.0005	0.013	0.375	9.52	0.031	0.8	0.22	0.100	1340	6000	2750	12200

<sup>(1)</sup> Maximum shaft or housing fillet radius which bearing corners will clear.

### SHIELD AND SEAL COMBINATIONS



One Shield  
D



Two Shields  
DD



One Shield  
And Seal  
PD



Two Seals  
PP

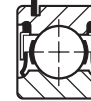

Two Seals  
WIRELOC  
PPG

Standard		Stainless		Width +0.000*, -.005* +0.00 mm, -.12 mm			One Shield And Seal PD			Two Seals PP			Two Seals (Wireloc) PPG			
One Shield D	Two Shields DD	One Shield D	Two Shields DD	fraction	in.	mm	fraction	in.	mm	fraction	in.	mm	fraction	in.	mm	
33KD3	33KDD3	A33KD3	A33KDD3	1/32	0.156	3.96	—	—	—	33PP3	—	—	1/32	0.156	3.96	
33KD4	33KDD4	—	—	1/64	0.172	4.37	—	—	—	—	—	—	—	—	—	
33KD5	33KDD5	A33KD5	A33KDD5	—	0.196	4.98	—	—	—	33PP5	33PPG5	—	—	0.196	4.98	
S1KD7	S1KDD7	AS1KD7	AS1KDD7	—	0.196	4.98	—	—	—	S1PP7	S1PPG7	—	—	0.196	4.98	
S1KD	S1KDD	AS1KD	AS1KDD	1/32	0.281	7.14	—	—	—	S1PP	S1PPG	—	—	1/32	0.281	7.14
S3KD	S3KDD	AS3KD	AS3KDD	1/32	0.281	7.14	—	—	—	S3PP	S3PPG	—	—	1/32	0.281	7.14
S5KD	S5KDD	AS5KD	AS5KDD	1/16	0.312	7.92	S5PD	S5PP	S5PPG	1/16	0.312	7.92	—	—	—	—
S7KD	S7KDD	—	—	1/32	0.344	8.74	—	—	—	S7PP	—	—	—	—	—	—
S8KD	S8KDD	—	AS8KDD	1/16	0.438	11.13	S8PD	S8PP	—	1/16	0.438	11.13	—	—	—	—
S9KD	S9KDD	—	—	1/2	0.500	12.70	—	—	—	—	—	—	—	—	—	—
S10KD	S10KDD	—	—	1/2	0.500	12.70	—	—	—	S10PP2	—	—	—	—	—	—
—	—	—	—	—	—	—	—	—	—	S12NPP	—	—	—	0.472	11.99	—



# Flanged Series

## CYLINDRICAL O.D.

Four sizes in the cylindrical O.D. series are offered in a flanged construction. Flanged bearings have integral shoulders for mounting in through-bored housings. These flanged bearings have straight outside diameters and are interchangeable with the corresponding unflanged sizes. The flanged group is available with double shields.

These bearings are electric motor quality for applications where extra quietness is a requirement.

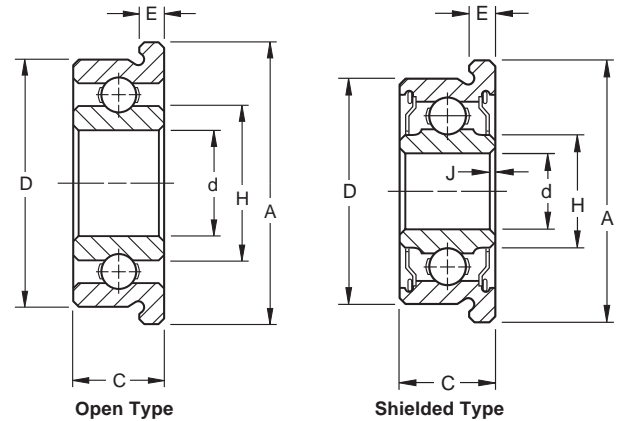

## DIMENSIONS – TOLERANCES

Bearing Number	Bore d		chamfer J x 45°		Outside Diameter D		Width C		Inner Ring Shoulder		Flange				Shielded Type Overall Width				Wt		Static Load Rating C <sub>0</sub>		Extended Dynamic Load Rating C <sub>E</sub>		
	open	shielded*	in.	mm	in.	mm	in.	mm	in.	mm	H	A	E	A	E	H	in.	mm	in.	mm	lbs.	kg.	lbs.	N	lbs.
F33K3	F33KDD3	0.1250	3.175	0.012	0.30	0.3750	9.525	0.156	3.96	0.202	5.13	0.440	11.18	0.030	0.76	0.156	3.96	0.183	4.65	0.01	0.005	48	212	160	710
F33K5	F33KDD5	0.1875	4.762	0.012	0.30	0.5000	12.700	0.156	3.96	0.270	6.86	0.565	14.35	0.042	1.07	0.196	4.98	0.248	6.30	0.01	0.005	110	490	325	1430
FS1K7	FS1KDD7 <sup>(1)</sup>	0.2500	6.350	0.012	0.30	0.6250	15.875	0.196	4.98	0.349	8.86	0.690	17.53	0.042	1.07	0.196	4.98	0.332	8.43	0.01	0.005	125	560	365	1630
FS3K	FS3KDD <sup>(1)</sup>	0.3750	9.525	0.016	0.41	0.8750	22.225	0.219	5.56	0.517	13.13	0.969	24.61	0.062	1.57	0.281	7.14	0.475	12.06	0.02	0.009	310	1400	830	3650

<sup>(1)</sup> Also available in stainless steel. To specify, add prefix "A" before bearing number.

\* Also available with two contact seals. To specify, replace "KDD" in part number with "PP".

## TAPERED O.D.

The F Flanged Series has shoulders integral with the bearings for mounting in through-bored housings. They are used where compactness is essential or where it is not desirable to machine housing shoulders. All sizes in this series have tapered outside diameters, and all are available with double shields.

These bearings are particularly suitable for such applications as precision instruments, packaging machinery, motion picture projectors and the like. Several sizes in this series are manufactured in both standard bearing quality, chromium-alloy, high carbon steel and stainless steel, as indicated in the tables. To specify stainless steel, use the prefix A before the basic bearing number. Example: AF4.

These bearings are electric motor quality for applications where extra quietness is a requirement.

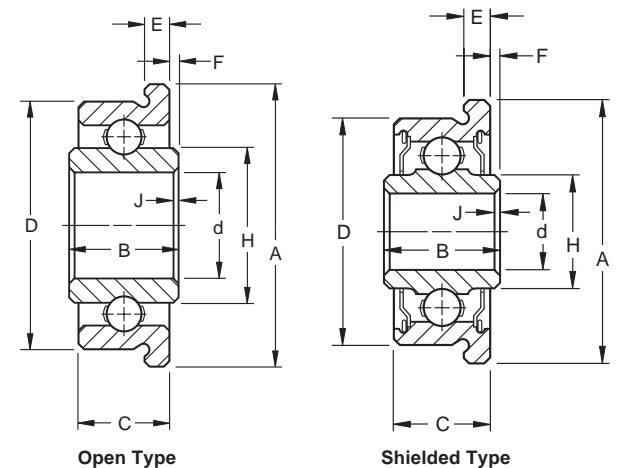

## DIMENSIONS – TOLERANCES

Bearing Number	Bore d		chamfer J x 45°		Outside Diameter D		Inner Width B		Ring Widths				Flange				Wt		Static Load Rating C <sub>0</sub>		Extended Dynamic Load Rating C <sub>E</sub>						
	open	shielded	in.	mm	in.	mm	in.	mm	Project F	H <sup>(3)</sup>	Outer Width C	taper per foot	A	E	in.	mm	in.	mm	lbs.	kg.	lbs.	N	lbs.	N			
F2 <sup>(1)</sup>	—	0.1875	4.762	0.010	0.25	0.4382	11.130	0.189	4.80	0.016	0.41	0.273	6.93	0.163	4.14	0.080	2.03	0.500	12.70	0.042	1.07	0.01	0.005	106	465	260	1160
—	F2DD-2	0.1250	3.175	0.010	0.25	0.3757	9.534	0.188	4.77	0.015	0.38	0.181	4.60	0.163	4.14	0.075	1.90	0.438	11.13	0.037	0.94	0.01	0.005	48	212	160	710
F3	—	0.1875	4.762	0.010	0.25	0.5632	14.305	0.218	5.54	0.015	0.38	0.273	6.93	0.195	4.95	0.080	2.03	0.625	15.88	0.042	1.07	0.01	0.005	110	490	325	1430
—	F3DD	0.1875	4.762	0.010	0.25	0.5632	14.305	0.250	6.35	0.015	0.38	0.245	6.22	0.226	5.74	0.068	1.73	0.625	15.88	0.042	1.07	0.01	0.005	110	490	325	1430
F4	F4DD	0.2500	6.350	0.010	0.25	0.6257	15.893	0.250	6.35	0.015	0.38	0.331	8.41	0.226	5.74	0.068	1.73	0.687	17.45	0.042	1.07	0.01	0.005	125	560	365	1630
F5	F5DD	0.3125	7.938	0.010	0.25	0.6882	17.480	0.250	6.35	0.015	0.38	0.410 <sup>(2)</sup>	10.41	0.226	5.74	0.068	1.73	0.750	19.05	0.042	1.07	0.01	0.005	196	865	540	2400

<sup>(1)</sup> Full type, no retainer. Not recommended for speeds over 500 RPM.

<sup>(2)</sup> H dimension is .381" (9.68 mm) for F5DD.

<sup>(3)</sup> Land dimension of the inner ring.



# ST Flangette Unit

Pressed steel housed units designed specifically for light duty applications are available in shaft sizes from 1/4 to 1/2 inch. This unit is designed to simplify mounting on side plate or frame type housings.

The unit consists of two identical steel stampings which house a clamp type bearing having a spherical O.D. outer ring. The spherical inside surface of each stamping mates with the spherical O.D. of the bearing to provide initial self-alignment at mounting. In addition, this unit offers the features of the basic clamp-type bearing. This series is available with sealed or shielded construction. Radial load capacity of the unit is 25% of the basic bearing's dynamic load rating at 33.3 R.P.M.

Bearings inspected to ABEC-1 tolerances except bore.

Recommended shaft tolerance: Nominal bore size to  $-.0005''$  resulting in  $.000''$  to  $.001''$  loose shaft fit.

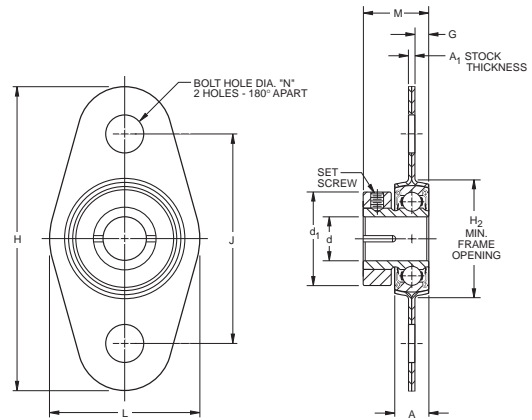

Unit Number	Bore** d		A		d <sub>1</sub>		H <sub>2</sub>		M		G		A <sub>1</sub>		H		L		J		N		Set Screw Thread*	Max. Radial Unit Load	
	in.	mm	in.	mm	in.	mm	in.	mm	in.	mm	in.	mm	in.	mm	in.	mm	in.	mm	in.	mm	in.	mm		lbs.	N
S1PPB7-3 ST	0.2500	6.350	3/32	5.556	1/16	14.287	25/32	19.844	0.430	10.922	0.079	2.007	0.0269	0.683	1 25/32	45.244	3/8	22.225	1 1/2	30.956	3/32	0.219	4-40	70	312
S3PPB15 ST	0.3125	7.937	3/32	7.144	25/32	19.844	1 1/32	27.781	0.562	14.275	0.107	2.718	0.0329	0.836	2 3/32	53.181	1 1/16	30.163	1 11/32	38.894	3/32	0.219	8-36	150	668
S3PPB5 ST	0.3750	9.525	3/32	7.144	25/32	19.844	1 1/32	27.781	0.562	14.275	0.107	2.718	0.0329	0.836	2 3/32	53.181	1 1/16	30.163	1 11/32	38.894	3/32	0.219	8-36	150	668
S5PPB2 ST	0.5000	12.700	3/16	7.937	25/32	23.019	1 1/32	32.544	0.625	15.875	0.120	3.048	0.0359	0.912	2 11/32	59.531	1 1/16	36.512	1 25/32	45.244	3/32	0.219	8-36	220	980

\* All setscrews are hex socket oval point, 6 fluted socket setscrews available upon request. Setscrews with fused plastic patch available at added cost.

\*\* Bore tolerance applies prior to collar assembly.

# RTF-Rubber Tire Flange Housed Unit

A synthetic, conductive elastomer of Durometer hardness 80-85 facilitates mounting of standard cylindrical O.D. bearings in side plate of frame type housings. A generous taper on the entrance corner of the rubber cartridge simplifies insertion of the unit into the side panel and assures reasonable squareness of the bearings when fully mounted. The bearing is positioned by the integral flange of the rubber cartridge. Resiliency of the elastomer accommodates wider than standard recommended housing bore tolerance; greater flexibility in adjusting to minor shaft and/or housing misalignment; and helps reduce airborne noise and structural vibration. Additional advantages of the RTF series are those offered by the features of the basic clamp-type bearing design. Due to the deflection characteristics of the elastomer, the radial and thrust ratings for the RTF series is 10% of the basic bearings dynamic load rating at 33.3 R.P.M.

Bearings inspected to ABEC-1 tolerances except bore.

Recommended shaft tolerance: Nominal bore size to  $-.0005''$  resulting in  $.000''$  to  $.001''$  loose shaft fit.

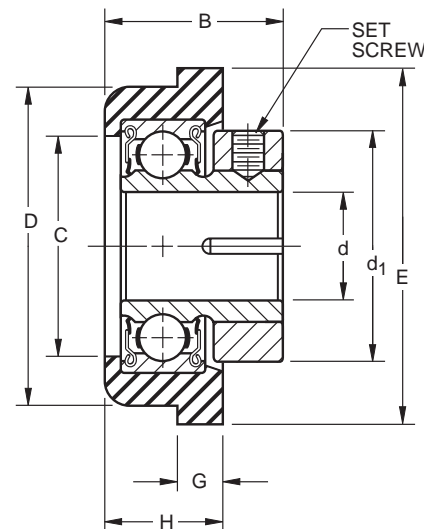

Unit number	Bore** d		D		C	d <sub>1</sub>	E	B	G	H	Set Screw Thread*	Max. Radial Unit Load							
	in.	mm	RTF O.D.	HSG Bore								lbs.	N						
S1PP73RTF	0.2500	6.350	±.005 ±.13mm	±.005 ±.13mm	1 1/32	13.494	3/16	14.287	3/8	22.225	1 9/32	11.906	3/64	1.984	1 1/64	7.541	4-40	26	116
S3PP16RTF	0.3125	7.937	±.005 ±.13mm	±.005 ±.13mm	3/4	19.050	25/32	19.844	1 1/32	30.956	3/8	15.875	3/32	3.969	1 1/32	10.319	8-36	58	258
S3PP4RTF	0.3750	9.525	±.005 ±.13mm	±.005 ±.13mm	3/4	19.050	25/32	19.844	1 1/32	30.956	3/8	15.875	3/32	3.969	1 1/32	10.319	8-36	58	258
S5PP2RTF	0.5000	12.700	±.005 ±.13mm	±.005 ±.13mm	1	25.400	25/32	23.019	1 11/32	38.894	45/64	17.859	3/32	3.969	1 1/32	11.906	8-36	88	392

\* All setscrews are hex socket oval point, 6 fluted socket setscrews available upon request. Setscrews with fused plastic patch available at added cost. \*\* Bore tolerance applies prior to collar assembly.



## Special Bearings

Pulley, guide roller and pinch roll bearings are available in several bore sizes providing the advantages of light weight, low inertia, low torque, and accurate running characteristics with minimum runout and wobble. Many of these units feature outer ring assemblies with integral molded "tires". The most commonly used tire materials are aluminum, steel, and a variety of engineered plastics such as nylon, polycarbonate, acetal resin, or polyurethane. The tire material and configuration are determined by the particular application requirements. Standard materials and shapes can be made available in many sizes; and, our Engineering Department is prepared to cooperate in testing any material you feel is suitable for your application.

Through Fafnir's universal ring design, sealed or shielded versions of the "special" are readily available with the most basic bearing sizes. Varying degrees of seal drag are offered to suit the sealing torque requirements dictated by the environmental conditions of the application.

The integral assembly design concept offers a complete package of bearings, housings, shaft, etc. assembled and ready to mount on the machine. Units are custom designed to solve customer assembly problems, minimize inventory of multiple components, and make purchasing's job easier in that one vendor is required instead of several, all these factors contributing to an overall cost savings.

The bearing units shown have been developed especially for business machine applications.

