



**1<sup>st</sup> Source Products, Inc.**

**Non Precision Bearings**

# CONTENTS

F SERIES, BEARINGS -----	2-6
S SERIES, BEARINGS -----	7-10
H SERIES, BEARINGS -----	11-15
M SERIES, BEARINGS & WHEELS -----	16-20
P SERIES, PLASTIC TIRE BEARINGS & WHEELS --	21-22
S SERIES, WHEELS -----	23-26
T SERIES, WHEELS -----	26
BALL TRANSFER UNITS -----	27-29
SPROCKET SERIES, -----	30-31
E-TRAC CHAIN & ACCESSORIES -----	32

# F SERIES, BEARINGS



Part No.	Dimension (inch/mm)						Ball No	Ball Dia	Rating lb/kg	Drawing #	Remark
	D	d	F	B	C	E					
FA068-04	0.678	0.252	0.72	0.20	0.11	5/16	11	1/8	20		
	17.22	6.40	18.3	5.1	2.8	7.9	11	3.19	9		
FA091-05H	0.908	0.317	0.97	0.25	0.09	11/32	12	5/32	35		
	23.06	8.05	24.6	6.4	2.4	8.7	12	3.97	16		
FA113-04	1.126	0.394	1.25	0.31	0.20	0.51	13	3/16	45		
	28.60	10.00	31.8	7.9	5.1	11.9	13	4.76	20		
FA113-05	1.126	0.317	1.25	0.31	0.13	7/16	13	3/16	45		
	28.60	8.05	31.8	7.9	3.2	11.1	13	4.76	20		
FA113-0601	1.126	0.380	1.25	0.31	0.13	0.71	13	3/16	45		
	28.60	9.65	31.8	7.9	3.2	18.0	13	4.76	20		
FA113-0602	1.126	0.380	1.25	0.31	0.13	0.82	13	3/16	45		
	28.60	9.65	31.8	7.9	3.2	20.7	13	4.76	20		
FA113-07	1.126	0.438	1.25	0.31	0.13	7/16	13	3/16	45		
	28.60	11.13	31.8	7.9	3.2	11.1	13	4.76	20		
FA113-08	1.126	0.501	1.25	0.31	0.13	7/16	13	3/16	45		
	28.60	12.73	31.8	7.9	3.2	11.1	13	4.76	20		
FA138-10	1.375	0.625	1.50	0.31	0.13	7/16	17	3/16	55		
	34.93	15.88	38.1	7.9	3.2	11.1	17	4.76	25		
FA138-12	1.375	0.750	1.50	0.31	0.13	7/16	17	3/16	55		
	34.93	19.05	38.1	7.9	3.2	11.1	17	4.76	25		
FA138-06	1.375	0.376	1.50	0.31	0.13	7/16	17	3/16	55		
	34.93	9.55	38.1	7.9	3.2	11.1	17	4.76	25		
FA138-08	1.375	0.501	1.50	0.31	0.13	7/16	17	3/16	55		
	34.93	12.73	38.1	7.9	3.2	11.1	17	4.76	25		
FA200-14H	2.000	0.875	2.13	0.41	0.90	1.31	16	9/32	200		
	50.80	22.23	54.0	10.4	22.9	33.3	16	7.14	91		
FA200-16	2.000	1.013	2.13	0.44	0.31	3/4	16	9/32	200		
	50.80	25.73	54.0	11.1	7.9	0.8	16	7.14	91		
FA250-16	2.500	1.013	2.68	0.50	0.38	7/8	19	5/16	260		
	63.50	25.73	68.0	12.7	9.5	0.9	19	7.94	118		

# F SERIES, BEARINGS

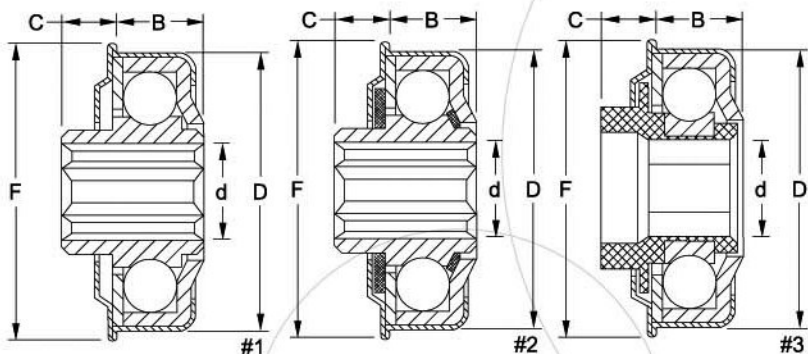

Part No.	Dimension (inch/mm)					Ball		Rating	Drawing	Remark
	D	d	F	B	C	No	Dia	lb/kg	#	
FA150-04	1.498	0.390	1.63	0.44	0.31	11	9/32	145	1	
	38.05	10.0	41.3	11.1	7.9	11	7.14	66		
FA150-07H	1.498	0.446	1.63	0.44	0.31	11	9/32	145	1	
	38.05	11.33	41.3	11.1	7.9	11	7.14	66		
FA150-07HS	1.498	0.446	1.63	0.44	0.31	11	9/32	145	2	polymer seal
	38.05	11.33	41.3	11.1	7.9	11	7.14	66		
FA150-07HP	1.498	0.446	1.63	0.44	0.31	11	9/32	145	3	conductive adaptor
	38.05	11.33	41.3	11.1	7.9	11	7.14	66		
FA153-07H	1.526	0.446	1.66	0.44	0.31	11	9/32	145	1	
	38.76	11.33	42.2	11.1	7.9	11	7.14	66		
FA153-07HS	1.526	0.446	1.66	0.44	0.31	11	9/32	145	2	polymer seal
	38.76	11.33	42.2	11.1	7.9	11	7.14	66		



Swagable, for 2.5" roller.

Following series available:  
 FB227, FM227, HB226,  
 HA227, HA234, HA236.

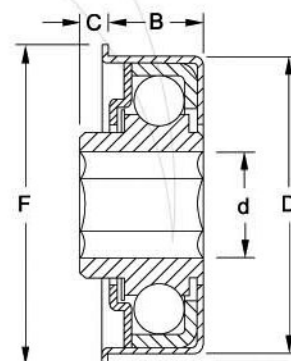

Part No.	Dimension (inch/mm)					Ball		Rating	Drawing	Remark
	D	d	F	B	C	No	Dia	lb/kg	#	
FA227-1001H	2.265	0.625	2.44	0.72	0.22	13	3/8	425		
	57.53	16.38	62.0	18.3	5.5	13	9.53	193		
FA227-1101H	2.265	0.698	2.44	0.72	0.22	13	3/8	425		
	57.53	17.74	62.0	18.3	5.5	13	9.53	193		

# F SERIES, BEARINGS

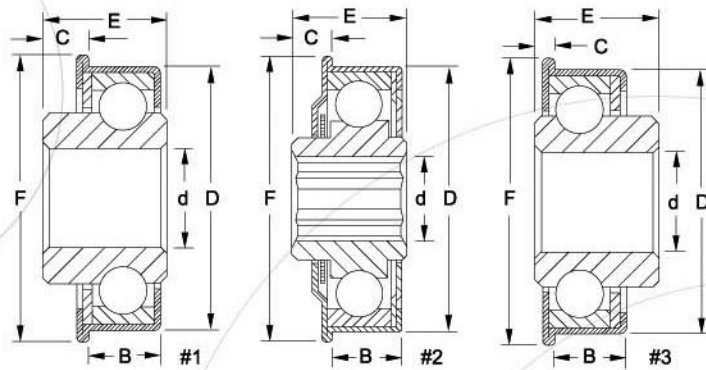

Part No.	Dimension (inch/mm)						Ball		Rating	Drawing	Remark
	D	d	F	B	C	E	No	Dia	lb/kg	#	
FB091-06	0.905	0.376	1.03	0.25	0.12		16	1/8	50	1	
	23.01	9.55	26.2	6.5	3.0	9.5	16	3.18	23		
FB113-05	1.126	0.317	1.25	0.31	0.06	3/8	13	3/16	180	1	
	28.60	8.05	31.8	7.9	1.6	9.5	13	4.76	82		
FB113-06	1.126	0.376	1.25	0.31	0.06	3/8	13	3/16	180	1	
	28.60	9.55	31.8	7.9	1.6	9.5	13	4.76	82		
FB113-08	1.126	0.501	1.25	0.31	0.28	19/32	13	3/16	180	1	
	28.60	12.73	31.8	7.9	7.1	15.1	13	4.76	82		
FB138-05	1.375	0.317	1.50	0.31	0.13	7/16	17	3/16	220	1	
	34.93	8.05	38.1	7.9	3.2	11.1	17	4.76	100		
FB138-08	1.375	0.501	1.50	0.31	0.13	7/16	17	3/16	220	1	
	34.93	12.73	38.1	7.9	3.2	11.1	17	4.76	100		
FB138-09H	1.375	0.567	1.50	0.31	0.13	7/16	17	3/16	220	1	
	34.93	14.40	38.1	7.9	3.2	11.1	17	4.76	100		
FB138-10	1.375	0.625	1.50	0.31	0.13	7/16	17	3/16	220	1	
	34.93	15.88	38.1	7.9	3.2	11.1	17	4.76	100		
FB163-07H	1.623	0.446	1.75	0.45	0.25	0.70	12	9/32	250	2	
	41.23	11.33	44.5	11.5	6.4	17.8	12	7.14	114		
FB184-08	1.841	0.787	2.00	0.47	0.18	0.73	12	5/16	306	3	
	46.76	20.00	50.8	11.9	4.6	18.5	12	7.94	139		
FB188-07H	1.875	0.446	2.00	0.50	0.31	13/16	12	5/16	306	1	
	47.63	11.84	50.8	12.7	7.9	20.6	12	7.94	139		
FB200-16	2.000	1.014	2.13	0.43	0.19	5/8	17	9/32	520	1	
	50.80	25.75	54.0	11.0	4.9	15.9	17	7.14	236		
FB250-16	2.500	1.014	2.68	0.50	0.38	7/8	19	5/16	660	1	
	63.50	25.75	68.0	12.7	9.5	22.2	19	7.94	300		



# F SERIES, BEARINGS

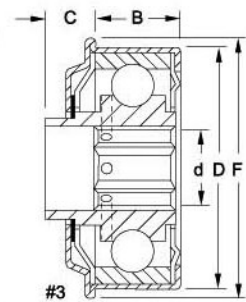
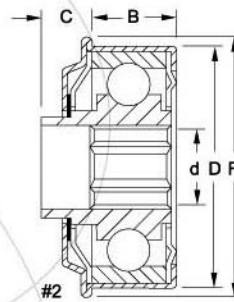
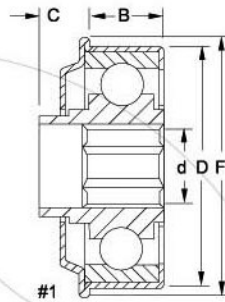

Part No.	Dimension (inch/mm)					Ball		Rating	Drawing	Remark
	D	d	F	B	C	No	Dia	lb/kg	#	
FB227-1000H	2.265	0.645	2.44	0.72	0.47	13	3/8	550	1	
	57.53	16.38	61.9	18.3	11.9	11	9.53	250		
FB227-1001H	2.265	0.645	2.44	0.81	0.47	13	3/8	550	2	polymer seal
	57.53	16.38	61.9	20.6	11.9	13	9.53	250		seal
FB227-1002H	2.265	0.645	2.44	0.81	0.47	13	3/8	550	3	polymer seal
	57.53	16.38	61.9	20.6	11.9	13	9.53	250		seal
FB227-1100H	2.265	0.698	2.44	0.72	0.47	13	3/8	550	1	
	57.53	17.73	61.9	18.3	11.9	11	9.53	250		
FB227-1101H	2.265	0.698	2.44	0.81	0.47	13	3/8	550	2	polymer seal
	57.53	17.73	61.9	20.6	11.9	13	9.53	250		seal
FB227-1102H	2.265	0.698	2.44	0.81	0.47	13	3/8	550	3	polymer seal
	57.53	17.73	61.9	20.6	11.9	13	9.53	250		seal

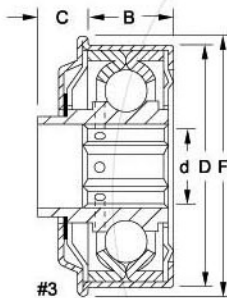
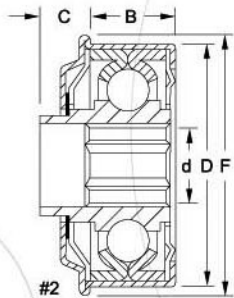
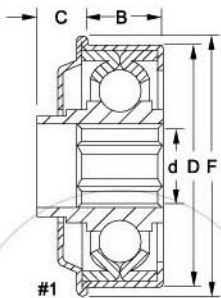

1<sup>st</sup> Source Products, Inc.

Part No.	Dimension (inch/mm)					Ball		Rating	Drawing	Remark
	D	d	F	B	C	No	Dia	lb/kg	#	
FM227-1000H	2.265	0.645	2.44	0.72	0.47	11	3/8	290	1	
	57.53	16.38	61.9	18.3	11.9	11	9.53	132		
FM227-1001H	2.265	0.645	2.44	0.81	0.47	11	3/8	290	2	polymer seal
	57.53	16.38	61.9	20.6	11.9	11	9.53	132		seal
FM227-1002H	2.265	0.645	2.44	0.81	0.47	11	3/8	290	3	polymer seal
	57.53	16.38	61.9	20.6	11.9	11	9.53	132		seal
FM227-1100H	2.265	0.698	2.44	0.72	0.47	11	3/8	290	1	
	57.53	17.73	61.9	18.3	11.9	11	9.53	132		
FM227-1101H	2.265	0.698	2.44	0.81	0.47	11	3/8	290	2	polymer seal
	57.53	17.73	61.9	20.6	11.9	11	9.53	132		seal
FM227-1102H	2.265	0.698	2.44	0.81	0.47	11	3/8	290	3	polymer seal
	57.53	17.73	61.9	20.6	11.9	11	9.53	132		seal

# F SERIES, BEARINGS

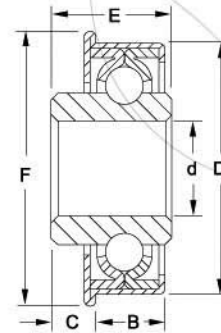

Part No.	Dimension (inch/mm)						Ball		Rating	Drawing	Remark
	D	d	F	B	C	E	No	Dia	lb/kg	#	
FM200-16	2.000	1.003	2.125	7/16	1/8	9/16	17	1/4	400		
	50.08	25.48	54.0	11.0	3.3	14.3	17	6.4	181		

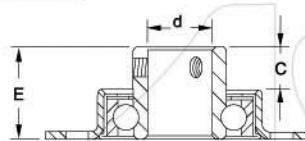
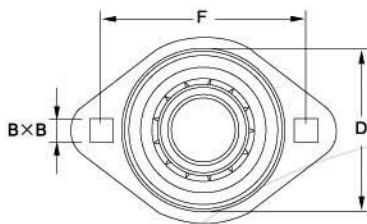

Part No.	Dimension (inch/mm)						Ball		Rating	Drawing	Remark
	D	d	F	B	E	C	No	Dia	lb/kg	#	
FLB184-1201A	2.50	0.75	1.97	0.28	1.13	0.53	13	9/32	250		
	63.5	19.1	50.0	7.1	28.6	13.5	13	7.14	114		

Double row deep groove design features good capacity in taking torque load.

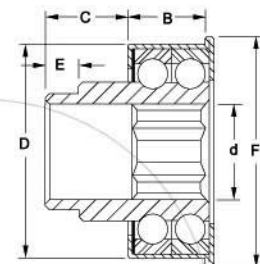
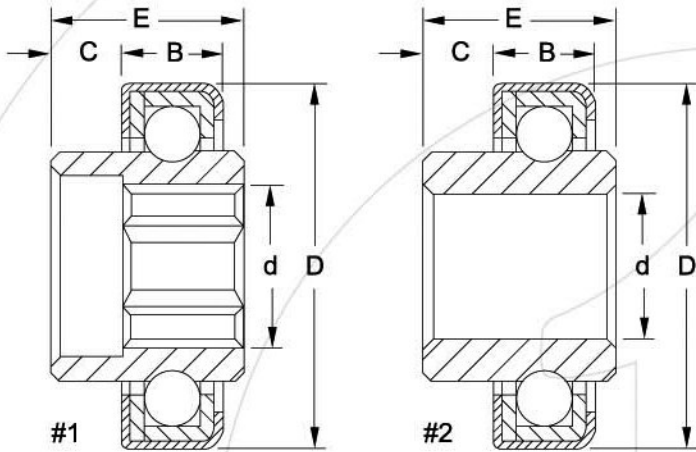

Photo shows assembly with mounting adaptor.

Part No.	Dimension (inch/mm)						Ball		Rating	Drawing	Remark
	D	d	F	B	E	C	No	Dia	lb/kg	#	
FBD227-14H	2.270	0.875	2.44	0.87	0.35	0.87	32	5/16	600		
	57.66	22.23	62.0	22.0	8.89	22.0	32	7.94	272		

# S SERIES, BEARINGS



1<sup>st</sup> Source Products, Inc.

Part No.	Dimension (inch/mm)					Ball No	Ball Dia	Rating lb/kg	Drawing #	Remark
	D	d	B	C	E					
SA081-05H	0.813	0.317	0.23	0.16	0.39	14	1/8	35	1	
	20.65	8.05	5.8	4.1	9.9	14	3.18	16		
SA091-07	0.908	0.446	0.25	0.13	0.38	17	1/8	35	2	
	23.06	11.33	6.4	3.2	9.6	17	3.18	16		
SA100-05H	0.994	0.317	0.25	0.25	0.50	18	1/8	40	1	
	25.25	8.05	6.4	6.4	12.7	18	3.18	18		
SA100-07H	0.994	0.442	0.25	0.25	0.50	18	1/8	40	1	
	25.25	11.23	6.4	6.4	12.7	18	3.18	18		
SA113-07H	1.126	0.446	0.36	0.14	0.50	13	3/16	45	1	
	28.60	11.33	9.1	3.6	12.7	13	4.76	18		

Part No.	Dimension (inch/mm)					Ball No	Ball Dia	Rating lb/kg	Drawing #	Remark
	D	d	B	C	E					
SA320-12	1.260	0.476	0.35		0.35	15	0.187	35	2	
	32.00	12.10	9.0		9.0	15	4.76	16		
SA320-1501	1.260	0.594	0.35		0.35	15	0.187	40	2	
	32.00	15.10	9.0		9.0	15	4.76	18		
SA320-1502H	1.260	0.594	0.35	0.14	0.49	15	0.187	40	1	
	32.00	15.10	9.0	3.5	12.5	15	4.76	18		



# S SERIES, BEARINGS

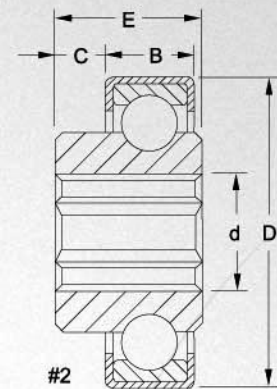
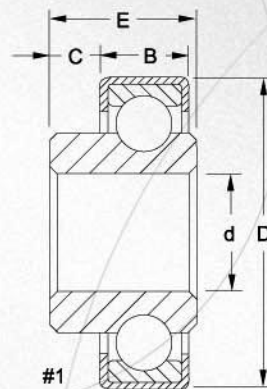

Part No.	Dimension (inch/mm)					Ball		Rating lb/kg	Drawing #	Remark
	D	d	B	E	C	No	Dia			
SB320-15	1.260	0.594	0.35	0.35		15	3/16	180	1	
	32.00	15.10	9.0	9.0		15	4.76	82		
SB320-14H	1.260	0.555	0.28	0.49	0.10	15	3/16	180	2	
	32.00	14.10	7.2	12.4	2.6	15	4.76	82		
SB400-17	1.575	0.673	0.47	0.47		13	1/4	240	1	
	40.00	17.10	12.0	12.0		13	6.35	110		
SB468-20	1.843	0.791	0.55	0.55		12	0.312	306	1	
	46.80	20.10	14.0	14.0		12	7.93	139		

Part No.	Dimension (inch/mm)					Ball		Rating lb/kg	Drawing #	Remark
	D	d	B	E	C	No	Dia			
SB112-05	1.120	0.317	0.29	0.29		13	3/16	180	1	
	28.45	8.05	7.4	7.4		13	4.76	81		
SB112-08	1.120	0.501	0.29	0.29		13	3/16	180	1	
	28.45	12.73	7.4	7.4		13	4.76	81		
SB113-0501	1.126	0.317	0.381	0.806	0.31	13	3/16	180	2	
	28.60	8.05	9.7	20.48	7.8	13	4.76	81		
SB138-08	1.375	0.501	0.36	0.50	0.14	17	3/16	200	2	
	34.93	12.73	9.1	12.7	3.6	17	4.76	90		
SB200-1001H	2.000	0.645	0.56	0.88	0.63	17	9/32	330	2	
	50.80	16.38	14.3	22.2	15.9	17	7.14	150		

# S SERIES, BEARINGS

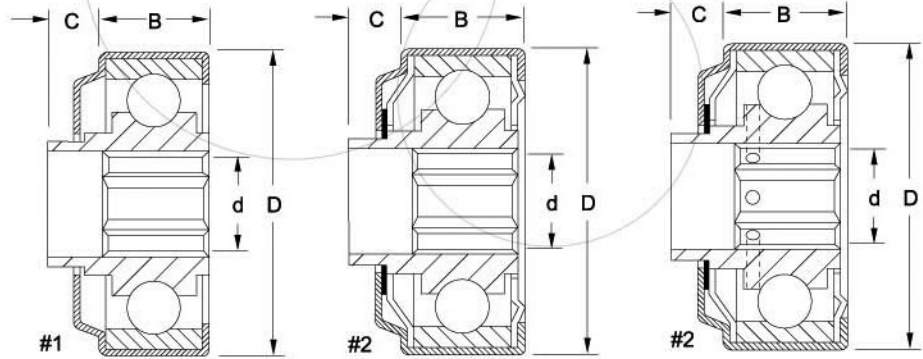

Part No.	Dimension (inch/mm)				Ball No	Ball Dia	Rating lb/kg	Drawing #	Remark
	D	d	B	C					
SB227-07H	2.265	0.446	0.91	0.38	13	3/8	550	2	
	57.53	11.33	23.0	9.5	13	9.53	250		
SB227-1000H	2.265	0.645	0.81	0.38	13	3/8	550	1	
	57.53	16.38	20.6	9.5	13	9.53	250		
SB227-1001H	2.265	0.645	0.91	0.38	13	3/8	550	2	polymer sealed
	57.53	16.38	23.0	9.5	13	9.53	250		
SB227-1002H	2.265	0.645	0.91	0.38	13	3/8	550	3	polymer sealed
	57.53	16.38	23.0	9.5	13	9.53	250		
SB227-1100H	2.265	0.698	0.81	0.38	13	3/8	550	1	
	57.53	17.73	20.6	9.5	13	9.53	250		
SB227-1101H	2.265	0.698	0.91	0.38	13	3/8	550	2	polymer sealed
	57.53	17.73	23.0	9.5	13	9.53	250		
SB227-1102H	2.265	0.698	0.91	0.38	13	3/8	550	3	polymer sealed
	57.53	17.73	23.0	9.5	13	9.53	250		

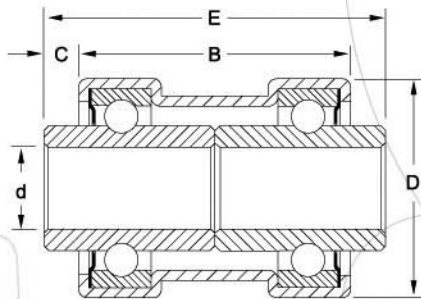

Part No.	Dimension (inch/mm)					Ball No	Ball Dia	Rating lb/kg	Drawing #	Remark
	D	d	B	E	C					
SBD277-082	1.092	0.325	1.27	1.58	0.37	24	3/16	300		
	27.7	8.05	32.2	40.2	9.3	24	4.76	136		
SBD277-098	1.092	0.387	1.27	1.58	0.37	24	3/16	300		
	27.7	9.63	32.2	40.2	9.3	24	4.76	136		

# S SERIES, BEARINGS

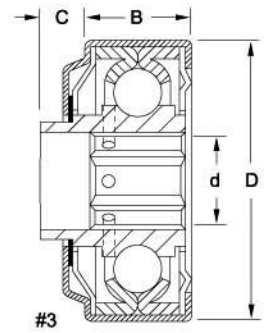
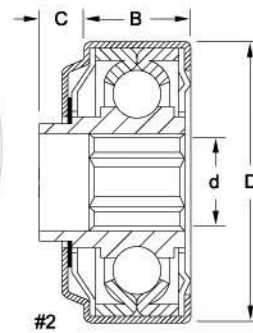
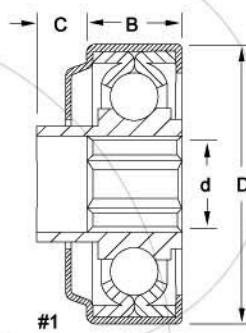

Part No.	Dimension (inch/mm)				Ball No	Ball Dia	Rating lb/kg	Drawing #	Remark
	D	d	B	C					
SM227-1000H	2.265	0.645	0.81	0.38	11	3/8	290	1	
	57.53	16.38	20.6	9.5	11	9.53	132		
SM227-1001H	2.265	0.645	0.91	0.38	11	3/8	290	2	polymer sealed
	57.53	16.38	23.0	9.5	11	9.53	132		
SM227-1002H	2.265	0.698	0.91	0.38	11	3/8	290	3	polymer sealed
	57.53	17.73	23.0	9.5	11	9.53	132		
SM227-1000H	2.265	0.698	0.81	0.38	11	3/8	290	1	
	57.53	17.73	20.6	9.5	11	9.53	132		
SM227-1101H	2.265	0.698	0.91	0.38	11	3/8	290	2	polymer sealed
	57.53	17.73	23.0	9.5	11	9.53	132		
SM227-1102H	2.265	0.698	0.91	0.38	11	3/8	290	3	polymer sealed
	57.53	17.73	23.0	9.5	11	9.53	132		

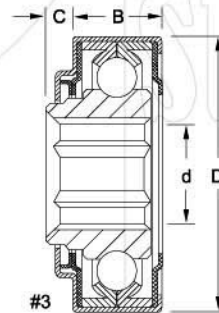
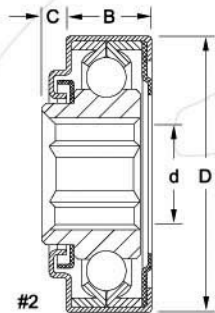
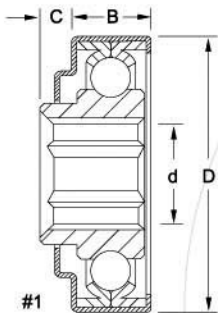

Part No.	Dimension (inch/mm)				Ball No	Ball Dia	Rating lb/kg	Drawing #	Remark
	D	d	B	C					
SM306-1701H	3.062	1.067	0.91	0.25	15	7/16	520	1	
	77.77	27.10	23.0	6.4	15	11.11	236		
SM306-1702H	3.062	1.067	0.97	0.25	15	7/16	520	2	
	77.77	27.10	24.6	6.4	15	11.11	236		
SM306-1703H	3.062	1.067	0.97	0.25	15	7/16	520	3	
	77.77	27.10	24.6	6.4	15	11.11	236		

# H SERIES, BEARINGS

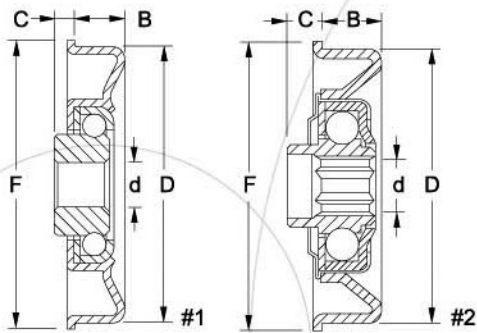

Part No.	Dimension (inch/mm)					Ball		Rating	Drawing	Remark
	D	d	F	B	C	No	Dia	lb/kg	#	
HA227-7H	2.265	0.446	2.48	0.51	0.30	11	9/32	145	2	
	57.53	11.33	63.5	13.0	7.6	11	7.14	66		
HA234-7H	2.335	0.446	2.48	0.48	0.28	11	9/32	145	2	
	59.31	11.33	63.5	12.3	7.2	11	7.14	66		
HA236-7H	2.355	0.446	2.48	0.51	0.30	11	9/32	145	2	
	59.82	11.33	63.5	13.0	7.6	11	7.14	66		

Part No.	Dimension (inch/mm)					Ball		Rating	Drawing	Remark
	D	d	F	B	C	No	Dia	lb/kg	#	
HA472-10	1.858	0.398	1.95	0.39	0.15	12	3/16	130	1	
	47.20	10.10	49.6	9.8	3.8	12	4.76	59		
HA472-08	1.856	0.319	1.95	0.39	0.15	12	3/16	130	1	
	47.20	8.10	49.6	9.8	3.8	12	4.76	59		
HA562-10	2.213	0.398	2.35	0.40	0.15	15	3/16	150	1	
	56.20	10.10	59.6	10.2	3.8	15	4.76	68		
HA570-10	2.244	0.398	2.36	0.40	0.15	15	3/16	150	1	
	57.00	10.10	60.0	10.2	3.8	15	4.76	68		

The HP Series provides high capacity with a low noise level and a conductive polymer adaptor.

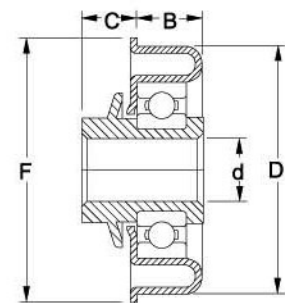

Part No.	Dimension (inch/mm)					Ball		Rating	Remark
	D	d	F	B	C	#	Noise	lb/kg	
HP178-7H	1.774	0.453	1.89	0.52	0.39	6002ZZ	<44 dB	350	
	45.06	11.50	48.1	13.1	10.0	6002ZZ		159	
HP175-7H	1.748	0.453	1.89	0.52	0.39	6002ZZ	<44 dB	350	
	44.40	11.50	48.1	13.1	10.0	6002ZZ		159	

# H SERIES, BEARINGS

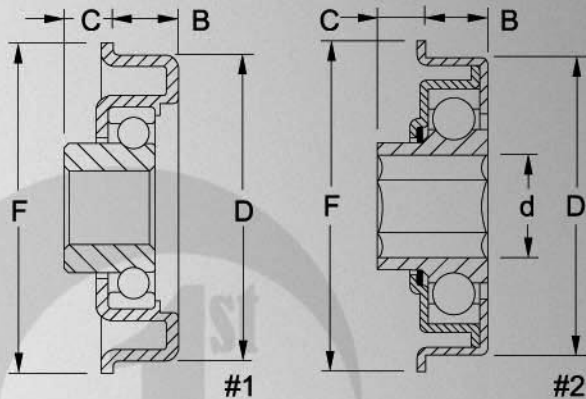

Part No.	Dimension (inch/mm)					Ball		Rating	Drawing	Remark
	D	d	F	B	C	No	Dia	lb/kg		
HB163-07H	1.618	0.446	1.74	0.43	0.15	13	3/16	175	1	
	41.10	11.32	44.2	11.0	4.0	13	4.76	80		
HB226-1001H	2.260	0.645	2.50	0.47	0.37	13	5/16	620	2	
	57.40	16.38	63.5	12.0	9.3	13	7.94	281		
HB226-1101H	2.260	0.698	2.50	0.47	0.37	13	5/16	620	2	
	57.40	17.73	63.5	12.0	9.3	13	7.94	281		

Part No.	Dimension (inch/mm)					Ball		Rating	Drawing	Remark
	D	d	F	B	C	No	Dia	lb/kg		
HB350-12	1.378	0.480	1.50	0.39	0.24	19	0.118	50	1	
	35.00	12.20	38.0	9.8	6.2	19	3.00	23		
HB477-12	1.878	0.480	1.97	0.45	0.24	15	3/16	185	1	
	47.70	12.20	50.0	11.5	6.2	15	4.76	84		
HB540-12	2.126	0.480	2.23	0.45	0.24	15	3/16	185	1	
	54.00	12.20	56.7	11.5	6.2	15	4.76	84		
HB542-12	2.134	0.480	2.35	0.42	0.28	16	3/16	200	1	
	54.20	12.20	59.6	10.7	7.0	16	4.76	91		
HB542-15	2.134	0.598	2.35	0.42	0.28	16	3/16	200	1	
	54.20	15.20	59.6	10.7	7.0	16	4.76	91		
HB694-15	2.732	0.598	2.95	0.62	0.29	13	5/16	290	1	
	69.40	15.20	75.0	15.7	7.3	13	7.94	132		
HB694-17	2.732	0.677	2.95	0.62	0.29	13	5/16	290	1	
	69.40	17.20	75.0	15.7	7.3	13	7.94	132		
HB694-20	2.732	0.795	2.95	0.62	0.29	13	5/16	290	1	
	69.40	20.20	75.0	15.7	7.3	13	7.94	132		

# H SERIES, BEARINGS

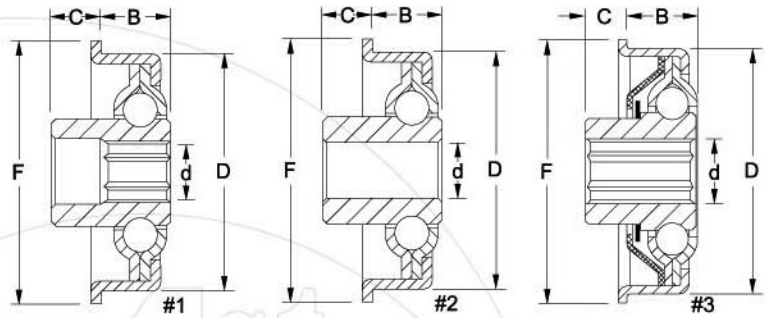

Part No.	Dimension (inch/mm)					Ball		Rating	Drawing	Remark
	D	d	F	B	C	No	Dia			
HM113-04	1.125	0.252	1.25	0.28	0.23	11	5/32	45	2	
	28.58	6.40	31.8	7.1	6.0	11	3.97	20		
HM113-04H	1.125	0.252	1.25	0.28	0.23	11	5/32	45	1	
	28.58	6.40	31.8	7.1	6.0	11	3.97	20		
HM113-05H	1.125	0.317	1.25	0.28	0.23	11	5/32	45	1	
	28.58	8.05	31.8	7.1	6.0	11	3.97	20		
HM127-04	1.273	0.252	1.38	0.28	0.23	11	5/32	47	2	
	32.33	6.40	34.9	7.1	6.0	11	3.97	21		
HM127-04H	1.273	0.252	1.38	0.28	0.23	11	5/32	47	1	
	32.33	6.40	34.9	7.1	6.0	11	3.97	21		
HM127-05H	1.273	0.317	1.38	0.28	0.23	11	5/32	47	1	
	32.33	8.05	34.9	7.1	6.0	11	3.97	21		
HM141-0401	1.403	0.252	1.50	0.40	0.23	13	3/16	75	2	
	44.99	6.40	38.1	10.2	6.0	13	4.76	34		
HM141-0501	1.403	0.317	1.50	0.40	0.23	13	3/16	75	2	
	44.99	8.05	38.1	10.2	6.0	13	4.76	34		
HM141-0502H	1.403	0.317	1.50	0.40	0.23	13	3/16	75	3	
	44.99	8.05	38.1	10.2	6.0	13	4.76	34		

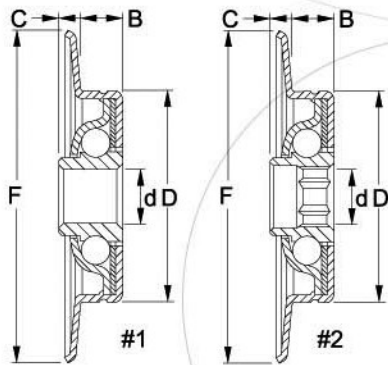

Part No.	Dimension (inch/mm)					Ball		Rating	Drawing	Remark
	D	d	F	B	C	No	Dia			
HM177-07F	1.774	0.446	2.81	0.39	0.28	11	1/4	130	1	
	45.06	11.33	71.4	9.9	7.1	11	6.35	59		
HM177-07HF	1.774	0.446	2.81	0.39	0.28	11	1/4	130	2	
	45.06	11.33	71.4	9.9	7.1	11	6.35	59		

# H SERIES, BEARINGS

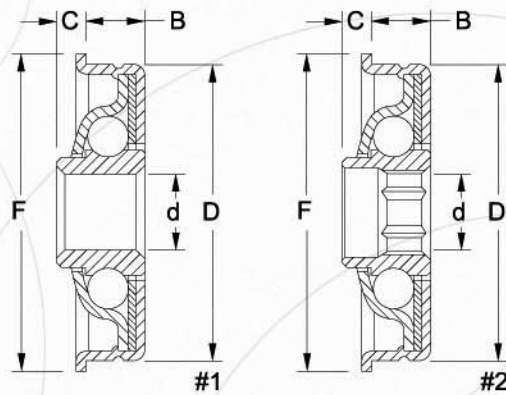

Part No.	Dimension (inch/mm)					Ball		Rating	Drawing	Remark
	D	d	F	B	C	No	Dia	lb/kg		
HM350-12	1.378	0.480	1.50	0.39	0.24	10	3/16	120	1	
	35.00	12.20	38.0	9.8	6.2	10	4.76	54		
HM407-12	1.602	0.480	1.73	0.44	0.15	10	1/4	120	1	
	40.70	12.20	44.0	11.2	3.8	10	6.35	54		
HM475-12	1.870	0.480	1.99	0.44	0.15	10	1/4	120	1	
	47.50	12.20	50.5	11.2	3.8	10	6.35	54		
HM572-12	2.252	0.480	2.38	0.44	0.23	10	1/4	120	1	
	57.20	12.20	60.5	11.2	5.8	10	6.35	54		

Part No.	Dimension (inch/mm)					Ball		Rating	Drawing	Remark
	D	d	F	B	C	No	Dia	lb/kg		
HM128-04	1.281	0.252	1.38	0.34	0.22	11	5/32	47	1	
	32.54	6.40	34.9	8.7	5.6	11	3.97	21		
HM128-05	1.281	0.317	1.38	0.34	0.22	11	5/32	47	1	
	32.54	8.05	35.0	8.7	5.6	11	3.97	21		
HM166-06	1.662	0.385	1.78	0.36	0.17	11	1/4	130	1	
	42.21	9.78	45.2	9.1	4.4	11	6.35	59		
HM166-07	1.662	0.446	1.78	0.36	0.17	11	1/4	130	1	
	42.21	11.33	45.2	9.1	4.4	11	6.35	59		
HM170-07	1.697	0.446	1.78	0.36	0.17	11	1/4	130	1	
	43.10	11.33	45.2	9.1	4.4	11	6.35	59		
HM172-06	1.722	0.385	1.86	0.36	0.17	11	1/4	130	1	
	43.74	9.78	47.2	9.1	4.4	11	6.35	59		
HM172-07	1.722	0.446	1.86	0.36	0.17	11	1/4	130	1	
	43.74	11.33	47.2	9.1	4.4	11	6.35	59		
HM175-06	1.747	0.380	1.86	0.36	0.17	11	1/4	130	1	
	44.37	9.65	47.2	9.1	4.4	11	6.35	59		
HM175-07	1.747	0.446	1.86	0.36	0.17	11	1/4	130	1	
	44.37	11.33	47.2	9.1	4.4	11	6.35	59		
HM177-04	1.774	0.252	1.90	0.36	0.17	11	1/4	130	1	
	45.06	6.40	48.3	9.1	4.4	11	6.35	59		
HM177-07	1.774	0.446	1.90	0.36	0.17	11	1/4	130	1	
	45.06	11.33	48.3	9.1	4.4	11	6.35	59		
HM187-06	1.872	0.385	2.00	0.42	0.17	11	1/4	130	1	
	47.55	9.78	50.8	10.7	4.4	11	6.35	59		
HM187-07	1.872	0.446	2.00	0.42	0.17	11	1/4	130	1	
	47.55	11.33	50.8	10.7	4.4	11	6.35	59		

# H SERIES, BEARINGS

Part No.	Dimension (inch/mm)					Ball		Rating	Drawing	Remark
	D	d	F	B	C	No	Dia	lb/kg		
HM128-04H	1.281	0.252	1.38	0.34	0.22	11	5/32	47	2	
	32.54	6.40	34.9	8.7	5.6	11	3.97	21		
HM128-05H	1.281	0.317	1.38	0.34	0.22	11	5/32	47	2	
	32.54	8.05	34.9	8.7	5.6	11	3.97	21		
HM166-06H	1.662	0.385	1.78	0.36	0.17	11	1/4	130	2	
	42.21	9.78	45.2	9.1	4.4	11	6.35	59		
HM166-07H	1.662	0.446	1.78	0.36	0.17	11	1/4	130	2	
	42.21	11.33	45.2	9.1	4.4	11	6.35	59		
HM170-07H	1.697	0.446	1.78	0.36	0.17	11	1/4	130	2	
	43.10	11.33	45.2	9.1	4.4	11	6.35	59		
HM172-06H	1.722	0.385	1.86	0.36	0.17	11	1/4	130	2	
	43.74	9.78	47.2	9.1	4.4	11	6.35	59		
HM172-07H	1.722	0.446	1.86	0.36	0.17	11	1/4	130	2	
	43.74	11.33	47.2	9.1	4.4	11	6.35	59		
HM175-06H	1.747	0.380	1.86	0.36	0.17	11	1/4	130	2	
	44.37	9.65	47.2	9.1	4.4	11	6.35	59		
HM175-07H	1.747	0.446	1.86	0.36	0.17	11	1/4	130	2	
	44.37	11.33	47.2	9.1	4.4	11	6.35	59		
HM177-07H	1.774	0.446	1.90	0.36	0.17	11	1/4	130	2	
	45.06	11.33	48.3	9.1	4.4	11	6.35	59		
HM187-06H	1.872	0.385	2.00	0.42	0.17	11	1/4	130	2	
	47.55	9.78	50.8	10.7	4.4	11	6.35	59		
HM187-07H	1.872	0.446	2.00	0.42	0.17	11	1/4	130	2	
	47.55	11.33	50.8	10.7	4.4	11	6.35	59		



1<sup>st</sup> Source Products, Inc.



# M SERIES, BEARINGS & WHEELS

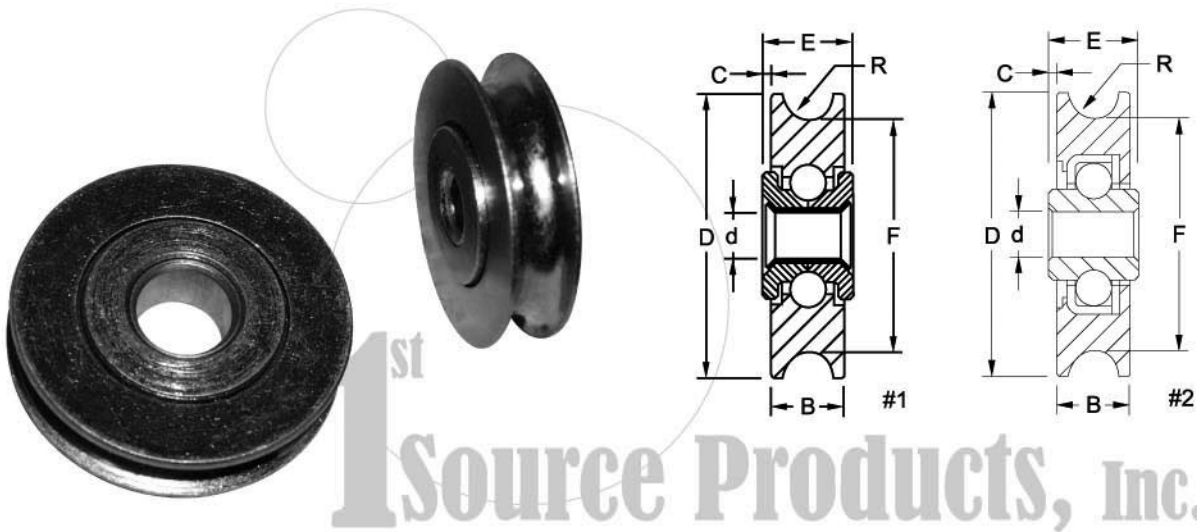

Part No.	Dimension (inch/mm)							Ball		Drawing	Remark
	D	d	F	B	E	C	R	No	Dia	#	
MA320-6	1.26	0.25	1.00	0.32	0.38	0.03	0.13	11	0.157	2	
	32.0	6.4	25.4	8.0	9.6	0.8	3.2	11	4.00		
MA350-6	1.38	0.25	1.13	0.32	0.38	0.03	0.13	11	0.157	2	
	35.0	6.4	28.6	8.0	9.6	0.8	3.2	11	4.00		
MA380-6	1.50	0.25	1.25	0.32	0.38	0.03	0.13	11	0.157	2	
	38.0	6.4	31.8	8.0	9.6	0.8	3.2	11	4.00		
MR320-6	1.26	0.25	1.00	0.32	0.38	0.03	0.13	11	0.157	1	
	32.0	6.4	25.4	8.0	9.6	0.8	3.2	11	4.00		
MR350-6	1.38	0.25	1.13	0.32	0.38	0.03	0.13	11	0.157	1	
	35.0	6.4	28.6	8.0	9.6	0.8	3.2	11	4.00		
MR380-6	1.50	0.25	1.25	0.32	0.38	0.03	0.13	11	0.157	1	
	38.0	6.4	31.8	8.0	9.6	0.8	3.2	11	4.00		

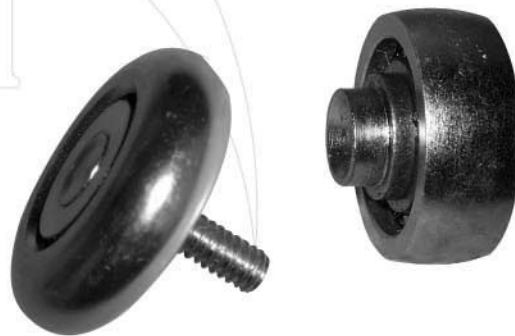
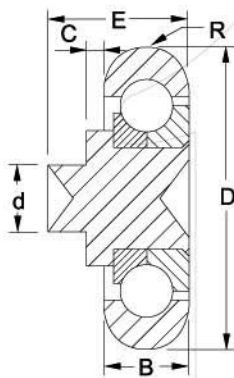

Part No.	Dimension (inch/mm)						Ball		Drawing	Remark
	D	d	B	E	C	R	No	Dia	#	
MR099-06ST	0.987	0.37	0.38	0.55	0.17	1.50	11	3/16		
	25.06	9.4	9.7	14.0	4.3	38.1	11	4.76		
MR150-04ST	1.500	0.25	0.25	0.87	0.06	0.13	11	3/16		
	38.10	6.4	6.4	22.1	1.5	3.3	11	4.76		

# M SERIES, BEARINGS & WHEELS

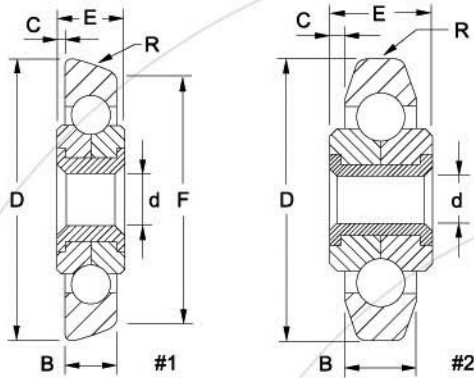

Part No.	Dimension (inch/mm)						Ball		Drawing	Remark
	D	d	B	E	C	R	No	Dia	#	
MR137-04	1.37	0.25	0.25	0.33	0.04	0.81	13	3/16	1	
	34.8	6.4	6.4	8.4	1.0	20.6	13	4.76		
MR149-04	1.49	0.25	0.38	0.54	0.08	0.81	10	1/4	2	
	37.7	6.4	9.7	13.7	2.0	20.6	10	6.35		



1<sup>st</sup> Source Products, Inc.

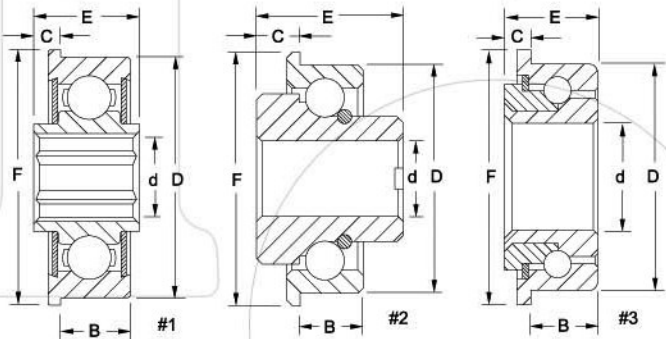

Part No.	Dimension (inch/mm)						Ball		Drawing	Remark
	D	d	F	B	E	C	No	Dia	#	
MF088-04	0.875	0.252	1.00	0.21	0.32	0.11	14	1/8	3	
	22.22	6.40	25.4	5.3	8.1	2.8	14	3.17		
MF091-05	0.906	0.313	1.03	0.25	0.50	0.13	16	1/8	2	
	23.01	7.95	26.2	6.4	12.7	3.2	16	3.17		
MF106-08	1.060	0.501	1.19	0.31	0.44	0.13	20	1/8	3	
	26.92	12.73	30.2	7.9	11.1	3.2	20	3.17		
MF113-06	1.125	0.375	1.25	0.31	0.72	0.41	13	3/16	2	
	28.58	9.53	31.8	7.9	18.3	10.3	13	4.76		
MF125-07	1.250	0.437	1.38	0.31	0.44	0.13	15	3/16	3	
	31.75	11.10	34.9	7.9	11.1	3.2	15	4.76		
MF138-10	1.375	0.625	1.50	0.38	0.47	0.09	17	3/16	3	
	34.93	15.88	38.1	9.5	11.9	2.4	17	4.76		
MF227-11H	2.267	0.698	2.38	0.51	0.94	0.20	9	13/32	1	
	57.58	17.73	60.3	13.0	23.9	5.1	9	10.32		

# M SERIES, BEARINGS & WHEELS



Part No.	Dimension (inch/mm)						Ball		Drawing	Remark
	D	d	B	E	C	R	No	Dia	#	
MR111-04	1.106	0.250	0.44	0.44		0.34	11	3/16	4	
	28.09	6.35	11.2	11.2		8.6	11	4.76		
MR130-03	1.300	0.180	0.24	0.28	0.02	0.41	13	3/16	4	
	33.02	4.57	6.1	7.1	0.5	10.4	13	4.76		
MR181-05	1.809	0.320	0.43	0.43		0.47	10	1/4	4	
	45.95	8.13	10.9	10.9		11.9	10	6.35		
MR213-05	2.126	0.320	0.33	0.33			12	5/16	2	MR54-8
	54.00	8.13	8.4	8.4			12	7.94		
MR225-05	2.25	0.320	0.44	0.53	0.09		14	1/4	3	
	57.15	8.13	11.2	13.5	2.3		14	6.35		
MR234-08	2.340	0.510		0.77		1.97	11	13/32	1	X348
	59.44	12.95		19.6		50.0	11	10.32		
MR318-16	3.180	1.020		0.94		2.76	13	1/2	1	X458
	80.77	25.91		24.0		70.1	13	12.70		

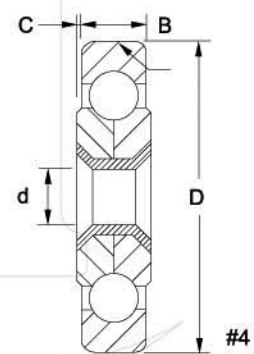
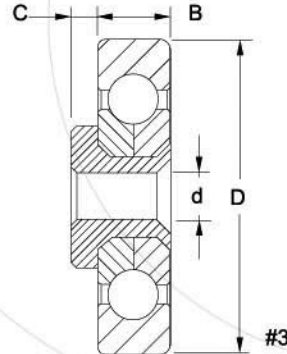
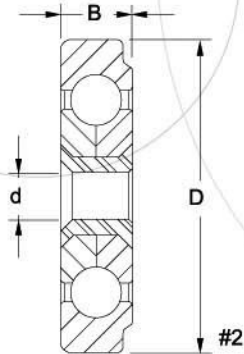
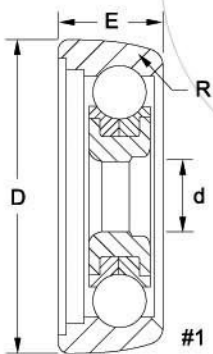

# M SERIES, BEARINGS & WHEELS

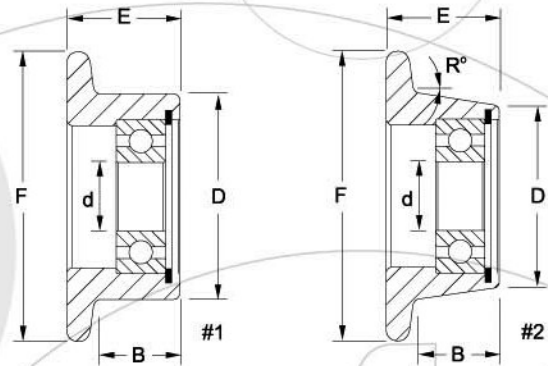

Part No.	Dimension (inch/mm)						Bearing	Drawing #	Remark
	D	d	F	B	E	R			
MF163	1.63	0.59	2.60	0.75	1.01		6202ZZ	1	
	41.4	15.0	66.0	19.1	25.7		6202ZZ		
MF163-1	1.63	0.59	2.60	0.75	1.01	9.50	6202ZZ	2	
	41.4	15.0	66.0	19.1	25.7	9.50	6202ZZ		
MF200	2.00	0.59	2.60	0.60	0.82		6202ZZ	1	
	50.8	15.0	66.0	15.2	20.8		6202ZZ		

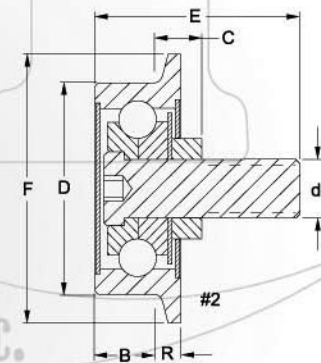
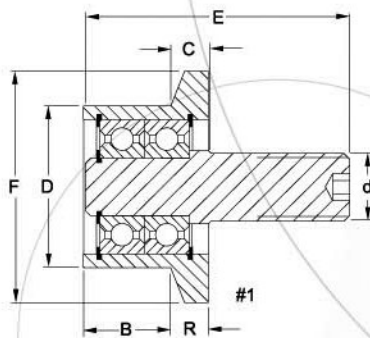

1<sup>st</sup> Source Products, Inc.

Part No.	Dimension (inch/mm)							Bearing/Ball		Drawing #	Remark
	D	d	F	B	E	C	R	No	Dia		
MF150-10ST	1.50	0.625	2.19	0.82	2.69	0.36	0.34	6000		1	
	38.1	15.8	55.6	20.8	68.3	9.14	8.64	6000			
MF231-10ST	2.31	0.63	2.90	0.73	2.28	0.43	0.20	11	13/32	2	
	58.7	15.9	73.7	18.5	57.9	10.9	5.1	11	10.32		

# M SERIES, BEARINGS & WHEELS

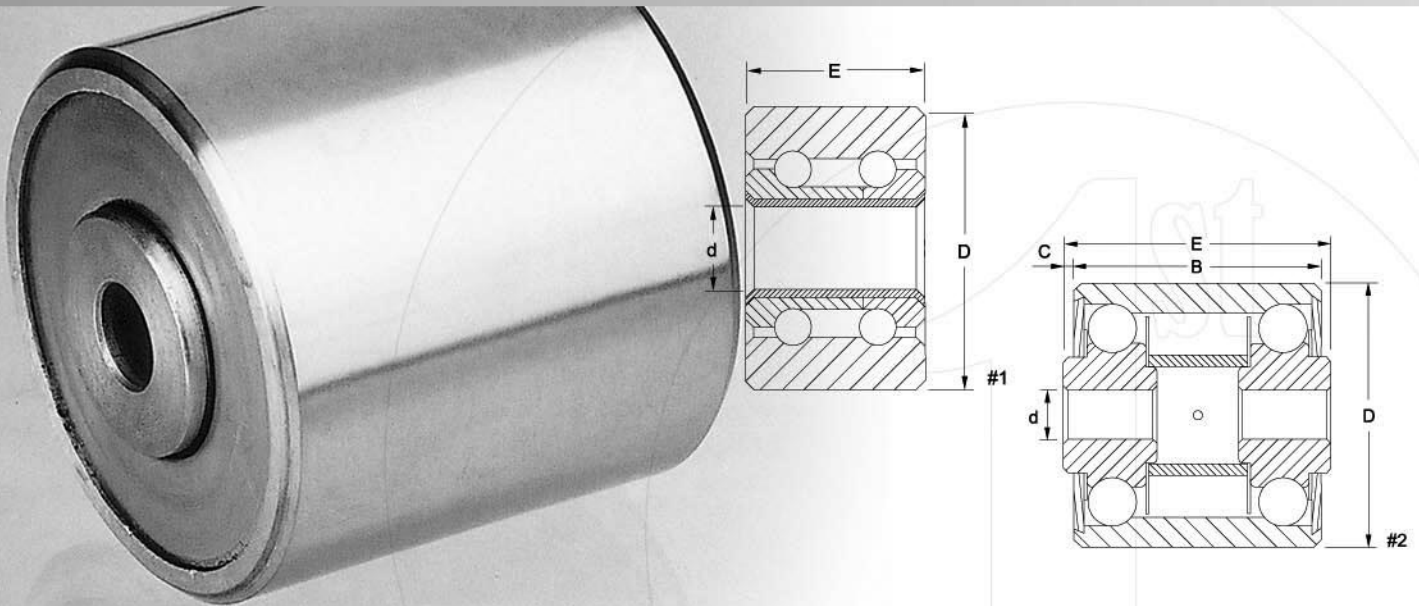

Part No.	Dimension (inch/mm)				Ball No	Ball Dia	Drawing #	Remark
	D	d	B	E				
MD075-4	0.75	0.25	0.94	1.06	26	1/8	1	
	19.1	6.4	23.9	26.9	26	3.17		
MD150-8	1.50	0.50	0.75	0.75	26	1/4	1	
	38.1	12.7	19.1	19.1	26	6.35		

Part No.	Dimension (inch/mm)					Ball No	Ball Dia	Rating lb/kg	Drawing #	Remark
	D	d	B	E	C					
MD275-08	2.750	0.501	2.56	2.75	0.09	22	1/2	2400	2	
	69.85	12.73	65.0	69.9	2.3	22	12.7	1090		
MD275-10	2.750	0.627	2.56	2.75	0.09	22	1/2	2400	2	
	69.85	15.93	65.0	69.9	2.3	22	12.7	1090		
MD275-12	2.750	0.752	2.56	2.75	0.09	22	1/2	2400	2	
	69.85	19.10	65.0	69.9	2.3	22	12.7	1090		
MD283-08	2.827	0.501	2.00	2.19	0.09	22	1/2	2400	2	
	71.80	12.73	50.8	55.6	2.3	22	12.7	1090		
MD283-10	2.827	0.627	2.00	2.19	0.09	22	1/2	2400	2	
	71.80	15.93	50.8	55.6	2.3	22	12.7	1090		
MD283-12	2.827	0.752	2.00	2.19	0.09	22	1/2	2400	2	
	71.80	19.10	50.8	55.6	2.3	22	12.7	1090		

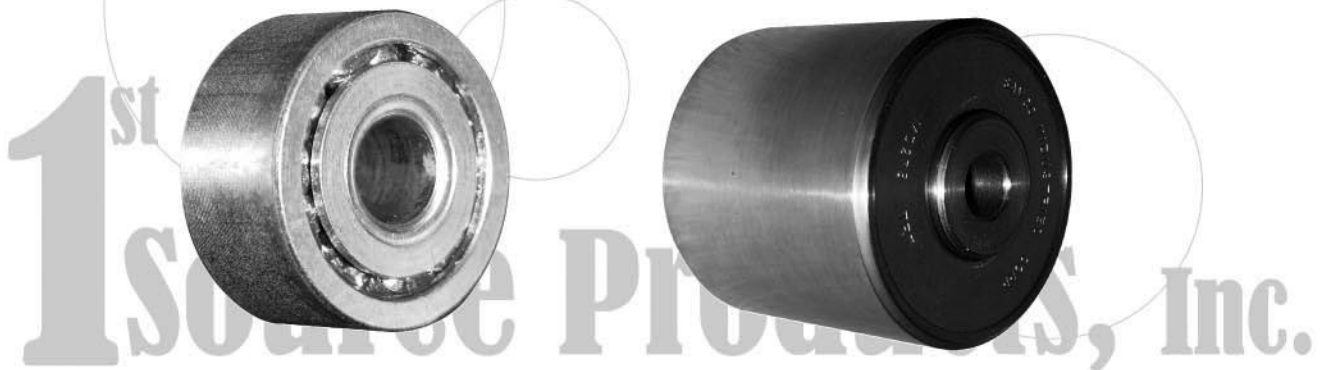

# P SERIES, PLASTIC TIRE BEARINGS & WHEELS

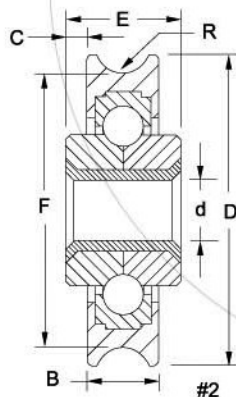
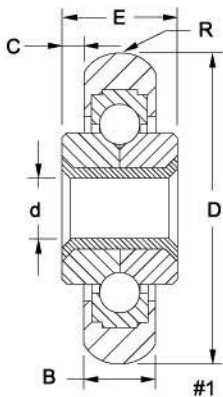

Part No.	Dimension (inch/mm)							Ball		Drawing	Remark
	D	d	F	B	E	C	R	No	Dia	#	
PR320-06	1.26	0.25	1.00	0.35	0.37	0.01	0.13	11	0.157	2	
	32.0	6.4	25.4	8.9	9.5	0.3	3.2	11	4.00		
PR350-06	1.38	0.25	1.13	0.35	0.37	0.01	0.13	11	0.157	2	
	35.0	6.4	28.6	8.9	9.5	0.3	3.2	11	4.00		
PR380-06	1.50	0.25	1.25	0.35	0.37	0.01	0.13	11	0.157	2	
	38.0	6.4	31.8	8.9	9.5	0.3	3.2	11	4.00		
PR100-04	1.00	0.25		0.25	0.30	0.05	0.15	13	1/8	1	
	25.4	6.4		6.4	7.6	1.3	3.8	13	3.17		
PR113-0401	1.13	0.25		0.28	0.34	0.03	0.15	13	5/32	1	
	28.7	6.4		7.1	8.6	0.8	3.8	13	3.97		
PR125-04	1.25	0.25		0.31	0.41	0.05		13	5/32	1	
	31.8	6.4		7.9	10.4	1.3		13	3.97		

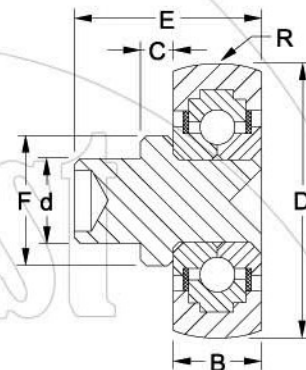

Part No.	Dimension (inch/mm)							Ball		Drawing	Remark
	D	d	F	B	E	C	R	No	Dia	#	
PR100-05ST	1.00	0.31	0.55	0.31	1.00	0.30	0.46	13	1/8		
	25.4	7.9	14.0	7.9	25.4	7.6	11.7	13	3.17		
PR112-07ST	1.12	0.43	0.55	0.38	1.00	0.31	0.32	13	5/32		
	28.4	10.9	14.0	9.7	25.4	7.9	8.1	13	3.97		
PR125-07ST	1.25	0.43	0.55	0.47	1.00	0.20	0.57	13	5/32		
	31.8	10.9	14.0	11.9	25.4	5.1	14.5	13	3.97		

# M SERIES, BEARINGS & WHEELS

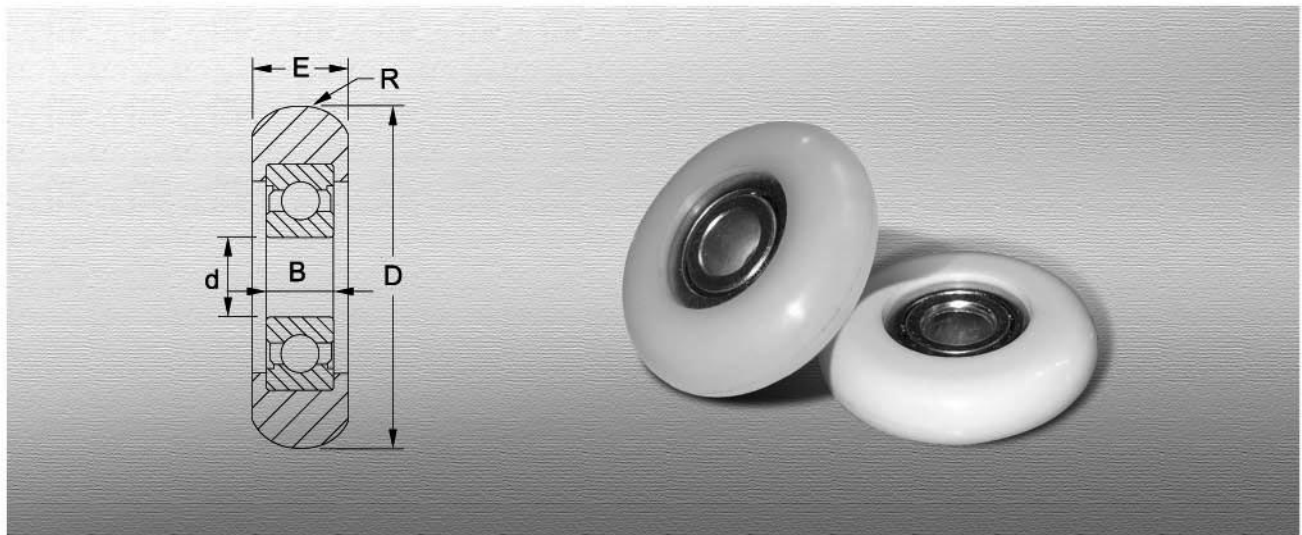

Part No.	Dimension (inch/mm)					Bearing	Remark
	D	d	B	E	R		
PL317-10	1.25	0.39	0.32	0.47	0.51	6000ZZ	
	31.7	10.0	8.0	12.0	13.0	6000ZZ	
PL450-10	1.77	0.39	0.35	0.53	0.59	6200ZZ	
	45.0	10.0	9.0	13.5	15.0	6200ZZ	



Part No.	Dimension (inch/mm)						Bearing	Remark
	D	d	F	B	E	C		
PL150-7H	1.49	0.45	1.66	0.46	0.88	0.42	6002ZZ	
	37.8	11.4	42.2	11.7	22.4	10.7	6002ZZ	
PL177-7H	1.77	0.45	1.83	0.61	0.95	0.34	6203ZZ	
	45.0	11.4	46.5	15.5	24.1	8.6	6203ZZ	

# M SERIES, BEARINGS & WHEELS

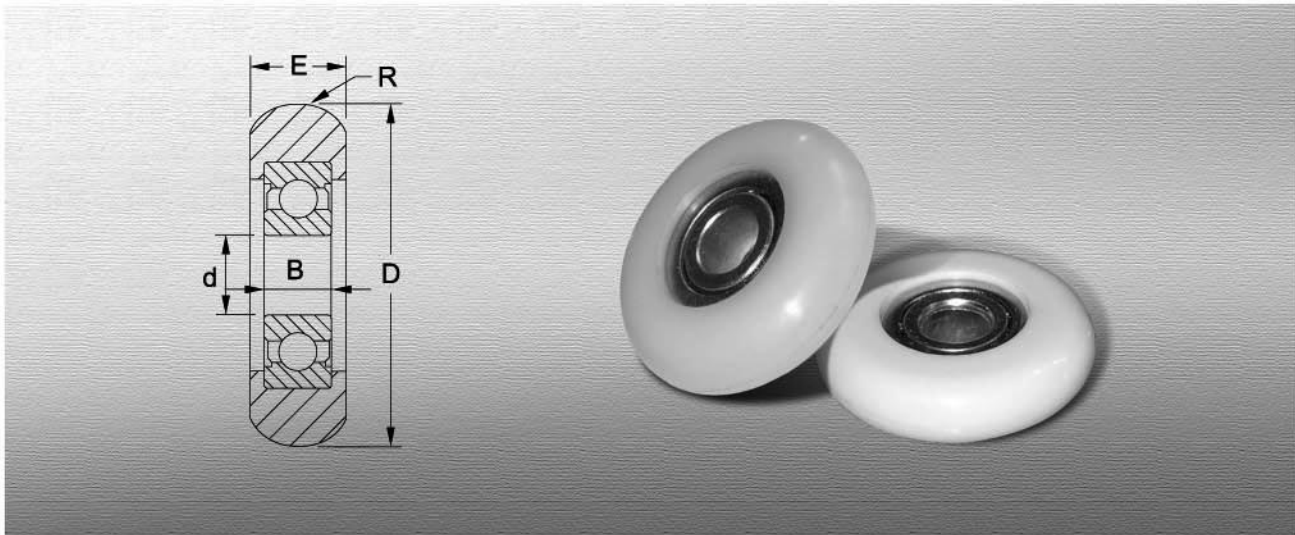

Part No.	Dimension (inch/mm)					Bearing	Remark
	D	d	B	E	R		
PL317-10	1.25	0.39	0.32	0.47	0.51	6000ZZ	
	31.7	10.0	8.0	12.0	13.0	6000ZZ	
PL450-10	1.77	0.39	0.35	0.53	0.59	6200ZZ	
	45.0	10.0	9.0	13.5	15.0	6200ZZ	



Part No.	Dimension (inch/mm)						Bearing	Remark
	D	d	F	B	E	C		
PL150-7H	1.49	0.45	1.66	0.46	0.88	0.42	6002ZZ	
	37.8	11.4	42.2	11.7	22.4	10.7	6002ZZ	
PL177-7H	1.77	0.45	1.83	0.61	0.95	0.34	6203ZZ	
	45.0	11.4	46.5	15.5	24.1	8.6	6203ZZ	



# S SERIES, WHEELS

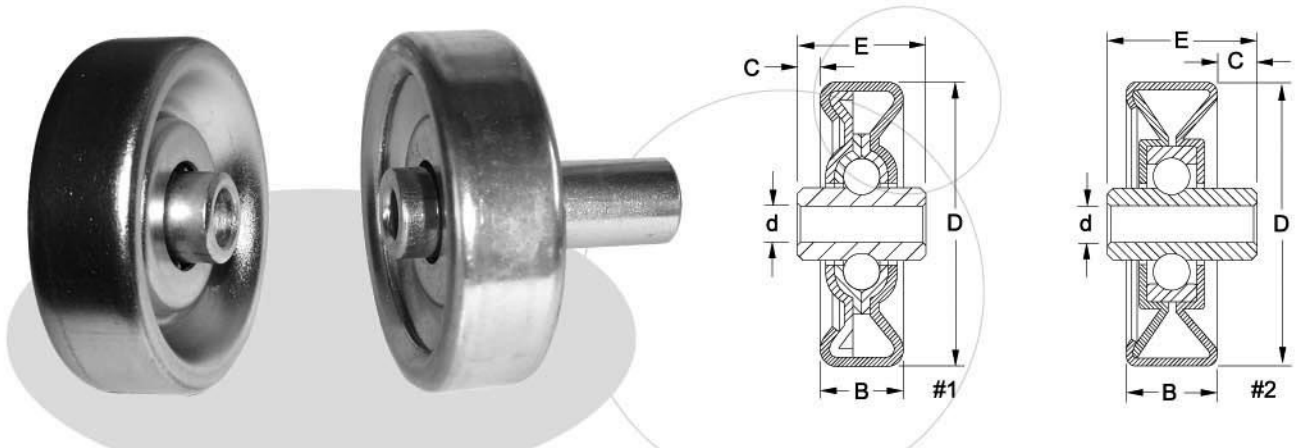

Part No.	Dimension (inch/mm)					Ball No	Ball Dia	Rating lb/kg	Drawing #	Remark
	D	d	B	E	C					
SK150-0401	1.50	0.252	0.51	0.81	0.15	8	1/4	40	1	
	38.1	6.40	13.0	20.6	3.8		6.35	18		
SK194-02AL (aluminum shell)	1.94	0.252	0.63	0.81	0.09	7	1/4	15	1	
	49.3	6.40	15.9	20.6	2.4		6.35	7		
SK194-0501	1.94	0.252	0.63	0.81	0.09	8	1/4	50	1	
	49.3	6.40	15.9	20.6	2.4		6.35	23		
SK194-0502	1.94	0.311	0.63	0.81	0.09	8	1/4	50	1	
	49.3	7.90	15.9	20.6	2.4		6.35	23		
SK194-0503	1.94	0.311	0.63	0.94	0.16	8	1/4	50	1	
	49.3	7.90	15.9	23.8	4.0		6.35	23		
SK194-0601	1.94	0.252	0.63	0.81	0.09	8	1/4	60	1	
	49.3	6.40	15.9	20.6	2.4		6.35	27		
SK194-0602	1.94	0.311	0.63	0.81	0.09	8	1/4	60	1	
	49.3	7.90	15.9	20.6	2.4		6.35	27		
SK194-0603	1.94	0.311	0.63	0.94	0.16	8	1/4	60	1	
	49.3	7.90	15.9	23.8	4.0		6.35	27		
SK194-1001	1.94	0.252	0.63	0.81	0.09	8	1/4	100	1	
	49.3	6.40	15.9	20.6	2.4		6.35	45		
SK194-1002	1.94	0.311	0.63	0.81	0.09	8	1/4	100	1	
	49.3	7.90	15.9	20.6	2.4		6.35	45		
SK194-1003	1.94	0.311	0.63	0.94	0.16	8	1/4	100	1	
	49.3	7.90	15.9	23.8	4.0		6.35	45		

**SKB227-0710**  
 D: 57.6 mm (2.27") d: 11.1mm (7/16")  
 B: 21.6 mm (0.85") E: 25.4 mm (1")  
 Load, 400 lbs

**SKU227-0704**  
 D: 57.6 mm (2.27")  
 d: 8.0 mm (0.32")  
 B: 17 mm (0.67")  
 E: 22.3 mm (0.88")  
 Load, 150 lbs

**SKU237-0704**  
 D: 60.3 mm (2.37") d: 8.0 mm (0.32")  
 B: 17 mm (0.67") E: 22.3 mm (0.88")  
 Load, 150 lbs

# S SERIES, WHEELS

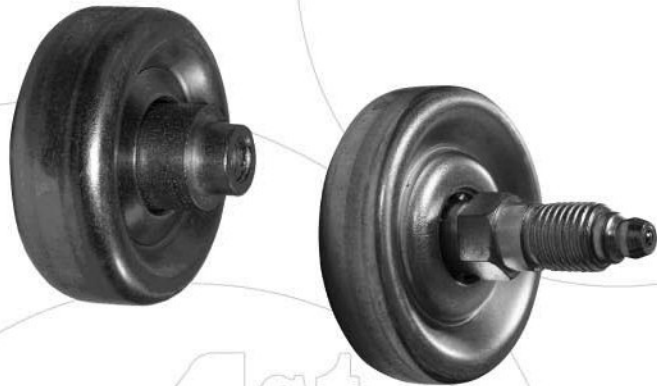
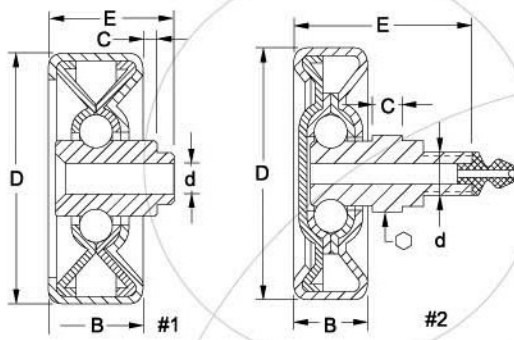

Part No.	Dimension (inch/mm)					Ball No	Ball Dia	Rating lb/kg	Drawing #	Remark
	D	d	B	E	C					
SK194-07GF	1.94	0.38	0.57	1.55	0.25	8	1/4	70	2	
	49.3	9.6	14.5	39.4	6.4	8	6.35	31		
SK480-06	1.89	0.26	0.71	0.95	0.24	10	1/4	150	1	
	48.0	6.5	18.0	24.0	6.0	10	6.35	68		

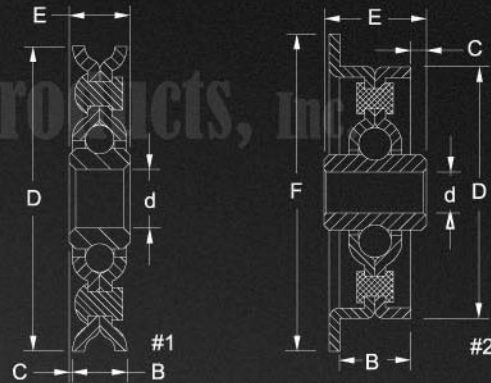

Part No.	Dimension (inch/mm)					Ball No	Ball Dia	Rating lb/kg	Drawing #	Remark
	D	d	B	E	C					
SP198-06	1.98	0.378	0.35	0.39	0.02	12	3/16	120	1	
	50.3	9.6	8.9	9.9	0.5	12	3.17	54		
SP237-06	2.37	0.378	0.35	0.39	0.02	12	3/16	120	1	
	60.2	9.6	8.9	9.9	0.5	12	3.17	54		

Part No.	Dimension (inch/mm)					Ball No	Ball Dia	Rating lb/kg	Drawing #	Remark
	D	d	B	E	C					
SG194-10	1.94	0.315	0.55	13/16	0.13	9	1/4	100	2	
	49.2	8.0	14.0	20.6	3.3	9	6.35	45		

# S SERIES, WHEELS

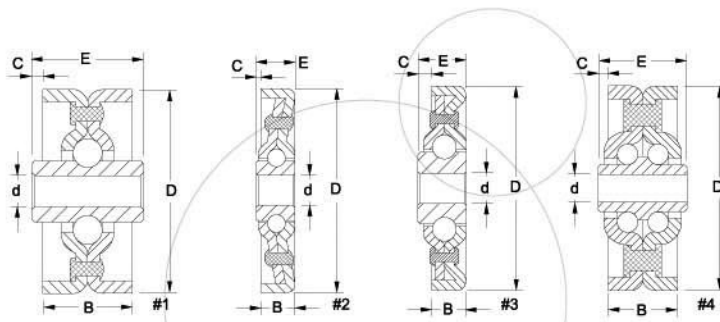

Source Products, Inc.

Part No.	Dimension (inch/mm)					Ball No	Rating lb/kg	Drawing #	Remark
	D	d	B	E	C				
SR152-10	1.52	0.32	0.55	0.81	0.13	8	3/16	100	1
	38.6	8.0	14.0	20.6	3.3	8	4.76	45	
SR166-1201	1.66	0.25	0.71	0.91	0.45	8	1/4	150	1
	42.2	6.4	18.0	23.0	11.4	8	6.35	68	
SR178-04	1.874	0.256	0.63	0.81	0.09	20	3/16	225	4
	47.60	6.50	16.0	20.6	2.3	20	4.76	102	
SR194-1501	1.94	0.32	0.55	0.81	0.13	9	1/4	150	1
	49.3	8.0	14.0	20.6	3.3	9	6.35	68	
SR215-12	2.15	0.32	0.35	0.40	0.05	11	3/16	120	2
	54.6	8.1	8.9	10.2	1.3	11	4.76	54	
SR445-1501	1.79	0.32	0.65	0.83	0.09	12	3/16	120	1
	45.5	8.2	16.4	21.0	2.3	12	4.76	54	
SR520-08	2.05	0.32	0.34	0.47	0.14	12	3/16	120	3
	52.0	8.2	8.5	12.0	3.5	12	4.76	54	

# T SERIES, BEARINGS

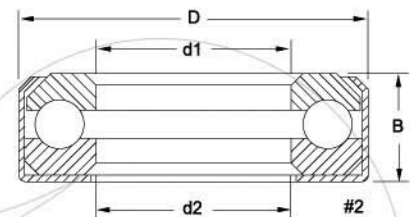
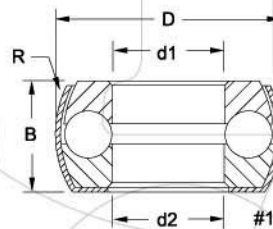

Part No.	Dimension (inch/mm)					Ball No	Rating Dia	Drawing #	Remark
	D	d1	d2	B	R				
TB146-07R	0.574	0.284	0.284	0.283	0.29	9	0.12	1	
	14.57	7.21	7.21	7.19	7.3	9	3.0		
TB200-08	0.768	0.315	0.319	0.345		8	3/16	2	
	19.50	8.00	8.10	8.76		8	4.76		
TB286-16	1.123	0.630	0.660	0.346		17	5/32	2	
	28.53	16.00	16.76	8.80		17	3.97		
TB630-31	2.480	1.185	1.185	0.756		12	7/16	2	
	63.00	30.10	30.10	19.20		12	11.11		

# BALL TRANSFER UNITS

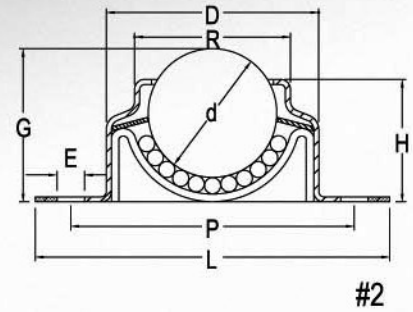
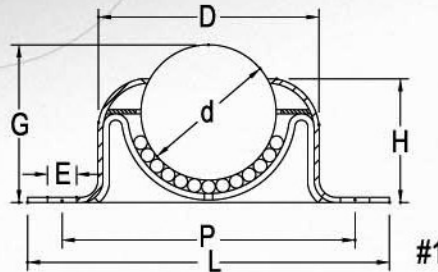
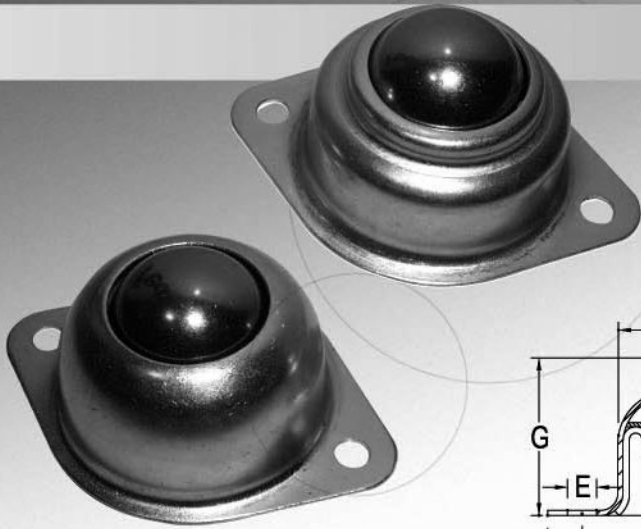

1<sup>st</sup> Source Products, Inc.

Part No.	Dimension (inch/mm)								Sub ball		Rating	Drawing	Remark
	D	d	P	L	E	G	H	R	No	Dia	lb/kg		
BT158-2	1.10	5/8	1.56	1.95	0.17	0.83	0.66	0.76	50	3/32	45	2	
	27.9	15.9	39.6	49.5	4.3	21.1	16.8	19.3	50	2.38	21		
BT254-1	1.65	1.00	2.20	2.72	0.21	1.19	0.95		65	1/8	125	1	
	41.9	25.4	55.9	69.1	5.3	30.2	24.1		65	3.17	57		
BT254-2	1.65	1.00	2.20	2.72	0.21	1.19	0.95	1.21	65	1/8	125	2	
	41.9	25.4	55.9	69.1	5.3	30.2	24.1	30.7	65	3.17	57		
BT317-1	2.05	1.25	2.71	3.35	0.27	1.46	1.14		60	3/16	250	1	
	52.1	31.8	68.8	85.1	6.9	37.1	29.0		60	4.76	114		

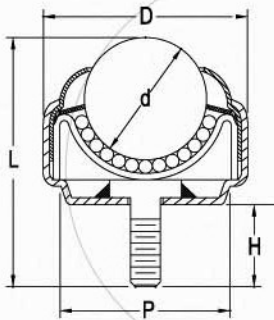

#1

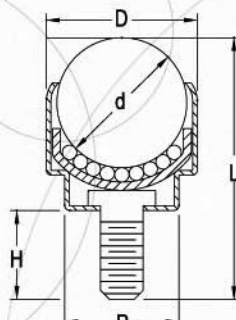

#2



Part No.	Dimension (inch/mm)					Sub Ball		Rating	Drawing	Remark
	D	d	P	L	H	No	Dia	lb/kg		
BT254-4	1.77	1.00	1.41	2.15	0.75	65	1/8	125	1	
	45.0	25.4	35.8	54.6	19.1	65	3.17	57		
BT286-4	1.88	1.13	1.57	2.37		100	1/8	200	1	
	47.8	28.6	39.9	60.2		100	3.17	91		
BT254-5	1.22	1.00	1.00	2.25	1.44	45	1/8	100	2	
	31.0	25.4	25.4	57.2	36.6	45	3.17	45		
BT286-5	1.30	1.13	1.00	2.22	1.45	100	1/8	200	2	
	33.0	28.6	25.4	56.4	36.8	100	3.17	91		

# BALL TRANSFER UNITS

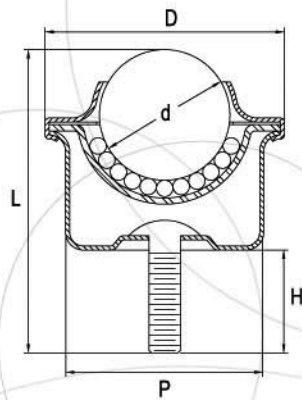

Part No.	Dimension (inch/mm)					Sub ball		Rating	Remark
	D	d	P	L	H	No	Dia		
BT254-3	1.81	1.00	1.50	2.41	0.87	65	1/8	50	
	46.0	25.4	38.1	61.2	22.1	65	3.17	21	

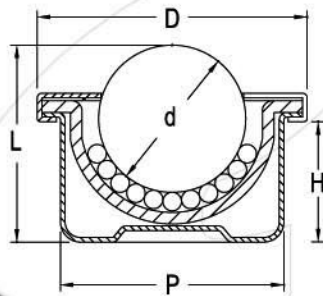

Part No.	Dimension (inch/mm)					Sub ball		Rating	Remark
	D	d	P	L	H	No	Dia		
BT254-7	1.84	1.00	1.52	1.34	0.82	65	1/8	125	
	46.7	25.4	38.6	34.0	20.8	65	3.17	57	

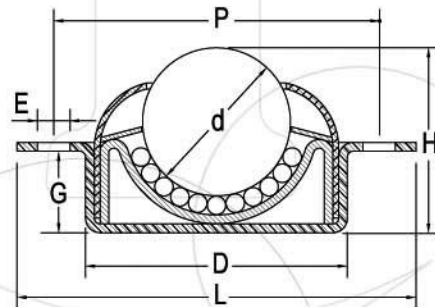

Part No.	Dimension (inch/mm)									Sub ball		Rating	Remark
	D	d	P	L	E	G	H	R	No	Dia			
BT254-8	1.77	1	2.20	2.70	0.21	0.55	1.25	0.46	65	1/8	125		
	45.0	25.4	55.9	68.6	5.3	14.0	31.8	11.7	65	3.17	57		

# BALL TRANSFER UNITS

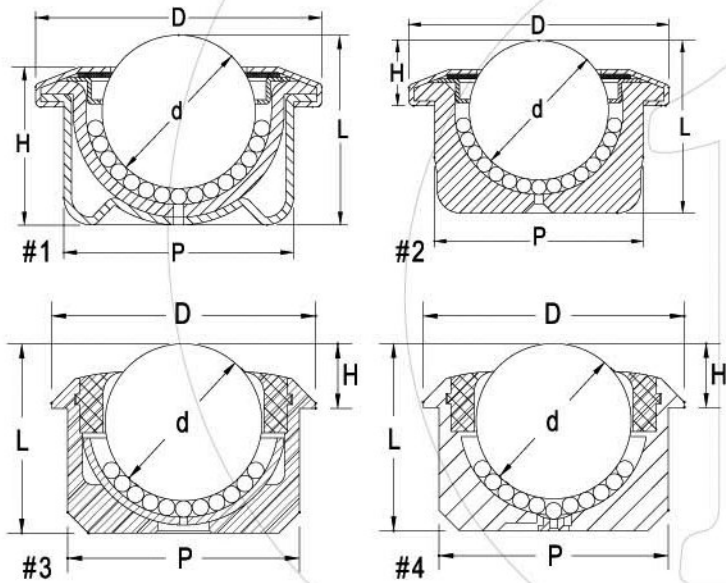

Part No.	Dimension (inch/mm)					Sub ball		Rating	Drawing	Remark
	D	d	P	L	H	No	Dia	lb/kg		
BT300-0301	2.20	1.19	1.77	1.46	0.55	100	1/8	330	1	
	55.9	30.2	45.0	37.1	14.0	100	3.17	150		
BT300-0302SS (stainless balls)	2.20	1.19	1.77	0.91	0.55	100	1/8	400	2	
	55.9	30.2	45.0	23.1	14.0	100	3.17	182		
BT300-0303SS (stainless balls)	2.00	1.19	1.76	1.43	0.49	100	1/8	400	3	
	50.8	30.2	44.6	36.4	12.4	100	3.17	182		
BT300-0304SS (stainless balls)	2.00	1.19	1.76	1.43	0.49	100	1/8	400	4	
	50.8	30.2	44.6	36.4	12.4	100	3.17	182		



Aluminum housing, stainless ball and support cup. Different anodized color housing available.

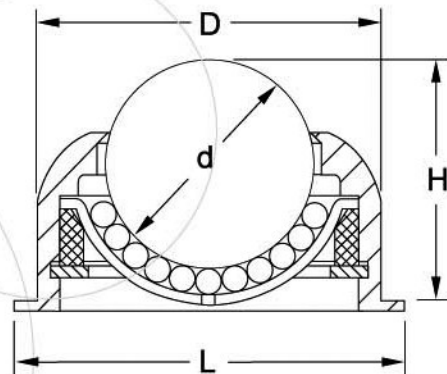

Part No.	Dimension (inch/mm)				Sub ball		Rating	Remark
	D	d	L	H	No	Dia	lb/kg	
BT254-9ALS	1.65	1.00	1.87	1.14	80	1/8	300	
	42.0	25.4	47.6	28.9	80	3.17	136	

# SPROCKETS

1 Source Products, Inc.

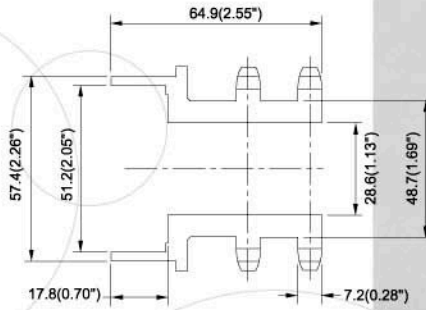
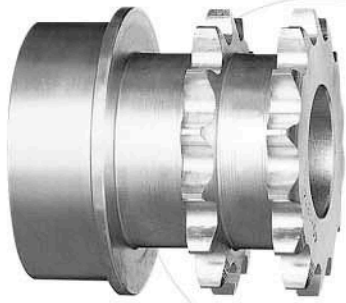

SKT4014D-6757

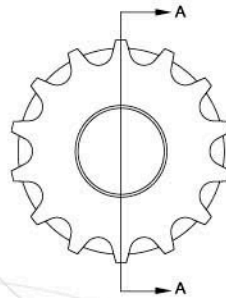
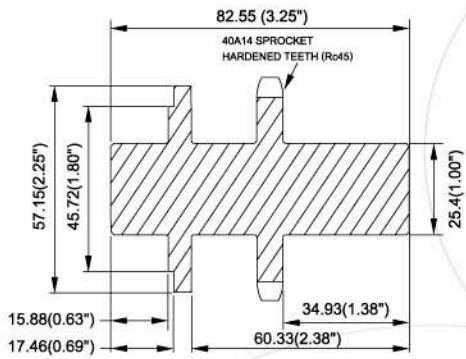
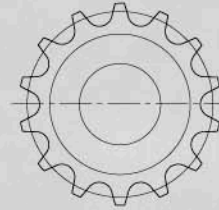

SKT4014S-8357

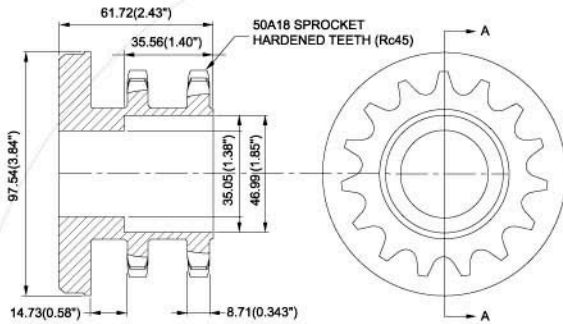

SKT5015D-6297

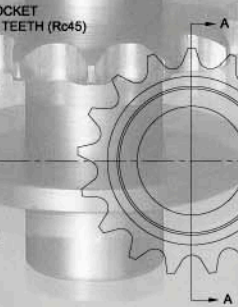
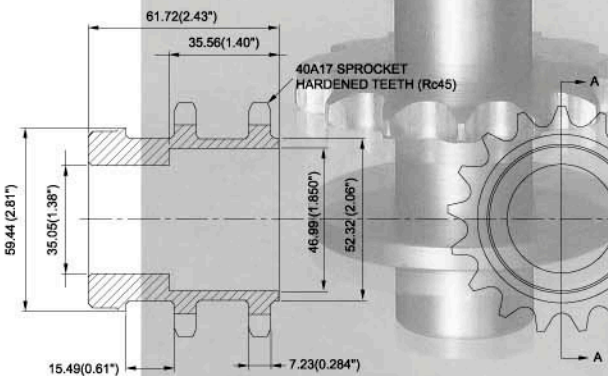

SKT4017-6259

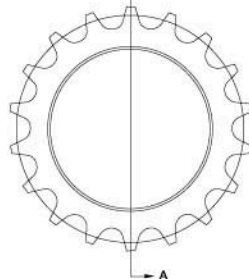
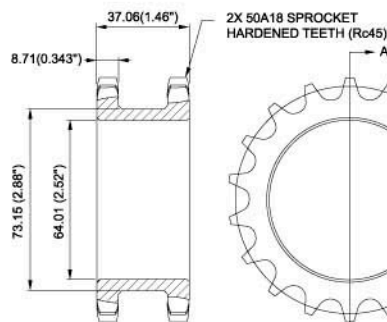

SKT5018D-3773

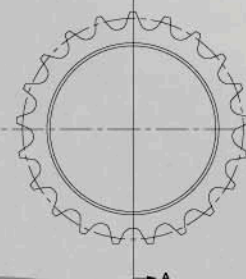
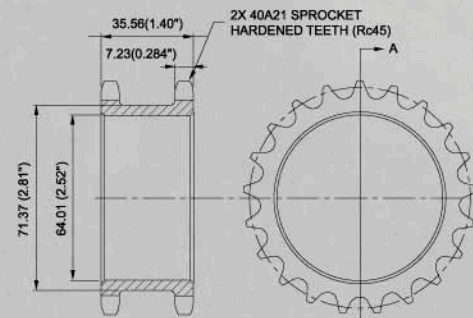

SKT4021S-3671

The one piece sprocket is made for conveyor rollers without welding, and with higher tolerance and durability. OEM production is available per customer drawings or samples.

# SPROCKETS

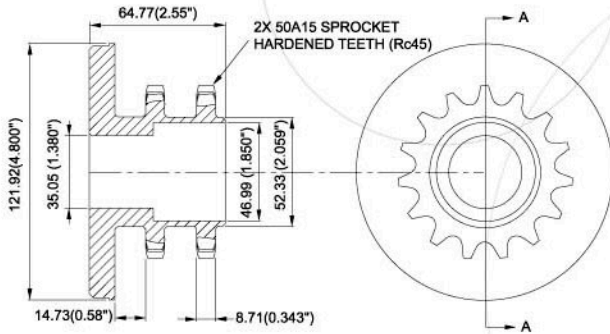

**SKT5015D-6512**

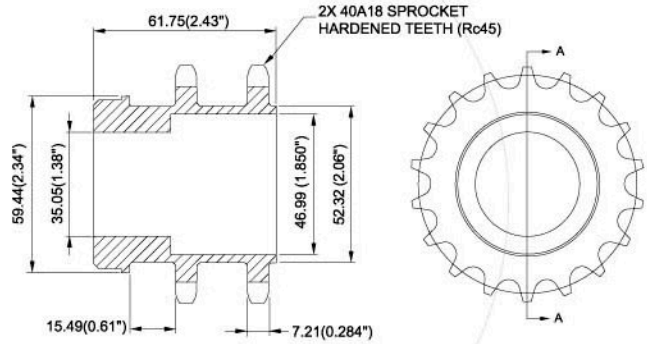

**SKT4018D-6259**

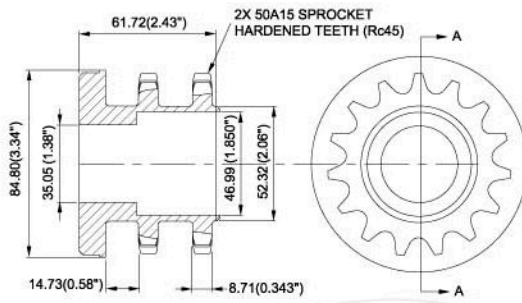

**SKT5015D-6295**

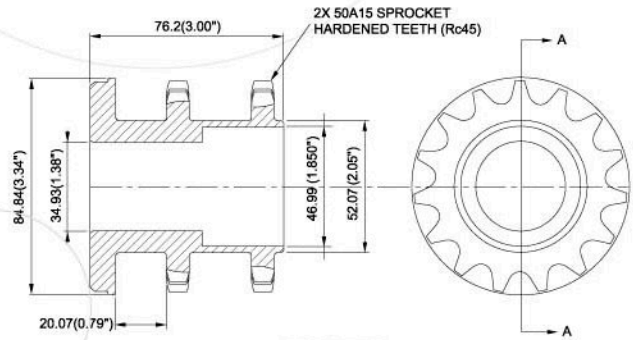

**SKT5015D-7684**

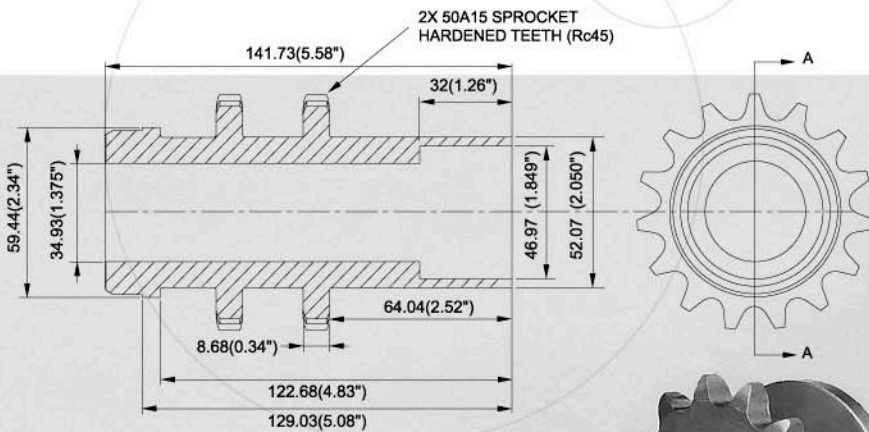

**SKT5015D-142**



1<sup>st</sup> Source Precision Inc



# E-TRAC CHAIN & ACCESSORIES

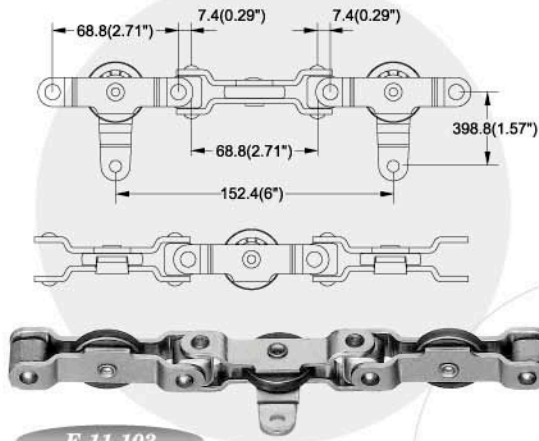

E-11-103

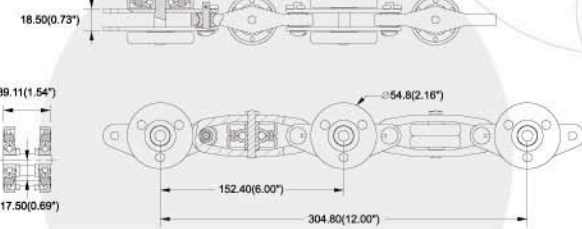

E-11-101

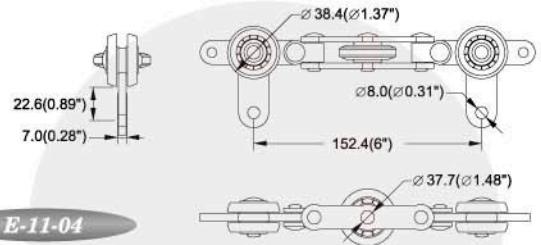

E-11-04

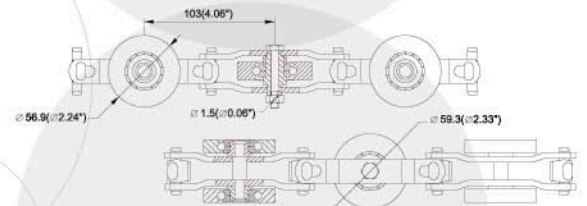

E-11-106

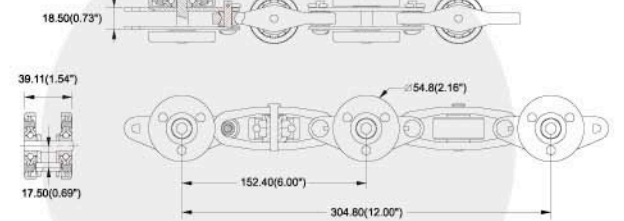

E-11-100

