

# **Cam Followers** (Stud Type Track Rollers) **Roller Followers** (Yoke Type Track Rollers)

High-quality products with long life and proven reliability.  
These series of cam followers and roller followers significantly  
improve cost efficiency.



**Significantly improve cost efficiency with long operating life and maintenance-free operation.**

Cam Followers and Roller Followers



**1. Long life**

A special thrust washer with improved anti-seizure properties of the sliding surface (bearing interior) is utilized.

**2. Maintenance-free**

Labyrinth seals enable maintenance-free operations.

**3. Resistant to heavy impact load**

A thick outer ring and crowned rollers provide resistance to shock loads.

**4. Match customer needs**

Available in two standard types to match customer needs: with-cage type for high-speed applications, or full-complement type for high-load applications.

Cam followers are available in two types; one with a cage for high speed, and the other with a full complement for heavy loads. In the cam follower with seals, a special thrust washer is employed for the sliding surface inside the bearing to improve heat-seizure resistance. Labyrinth sealing also ensures maintenance-free operation.

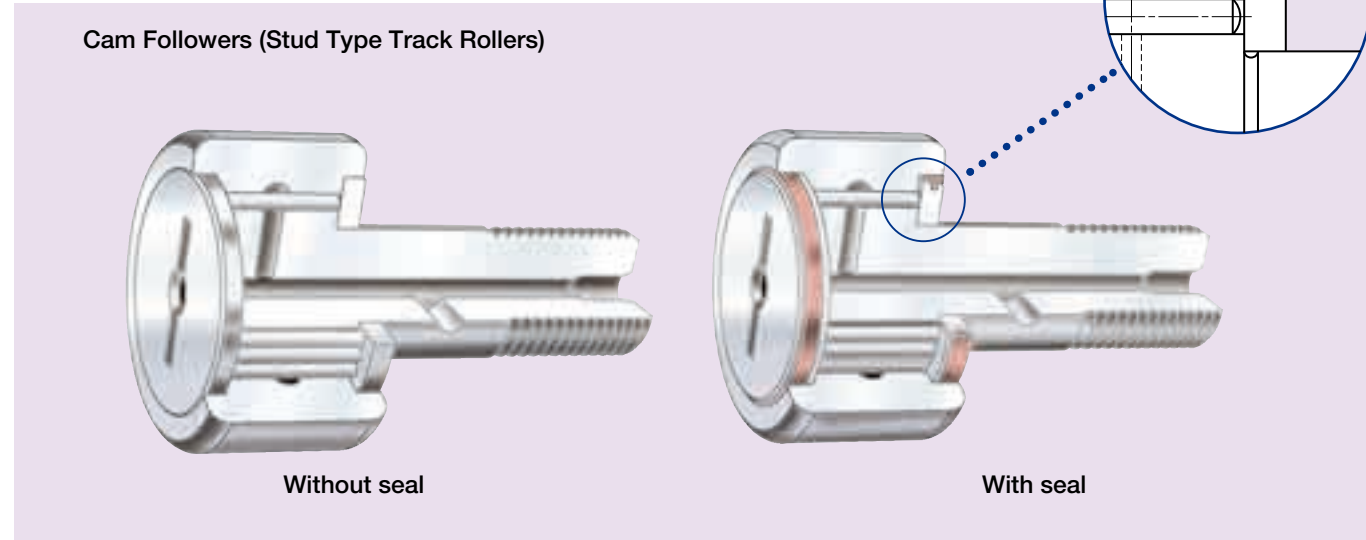

## 1. Types

Cam followers are available in the standard types shown in Table 1. These standard bearings have a screwdriver slot built into the stud head, while the outer rings have a cylindrical outside surface.

Cam followers, which are equipped with a thick outer ring, crowned rollers, and a stud with a hardened raceway surface, are especially tough and can sustain shock loads.

Table 1 Bearing Types

Code		Details
Metric	FCR	Full complement, without seal
	FCRS	Full complement, with seal and thrust washer
	FCJ	With cage, without seal
	FCJS	With cage, seal, and thrust washer
Inch	CR	Full complement, without seal
	CRS	Full complement, with seal and thrust washer

Bearings of the following unique specifications are available for manufacture upon request:

## 2. Special Specifications

- (1) Hexagonal socket on the stud head (refer to the Bearing Table)
- (2) Regular stud type with eccentric bushing stud (refer to the Bearing Table)
- (3) Threaded end of stud lubrication hole (refer to the Bearing Table)
- (4) An outer ring with a spherical outside surface (refer to page 4)

These specifications are indicated in the bearing number. Please use the Bearing Numbers as indicated on page 4 when placing orders. In addition to the above, products with their exposed surfaces treated with a black oxide layer to enhance corrosion resistance, as well as products of special shapes and specifications, can also be manufactured. Please contact NSK for further details.

## 3. Specification Number

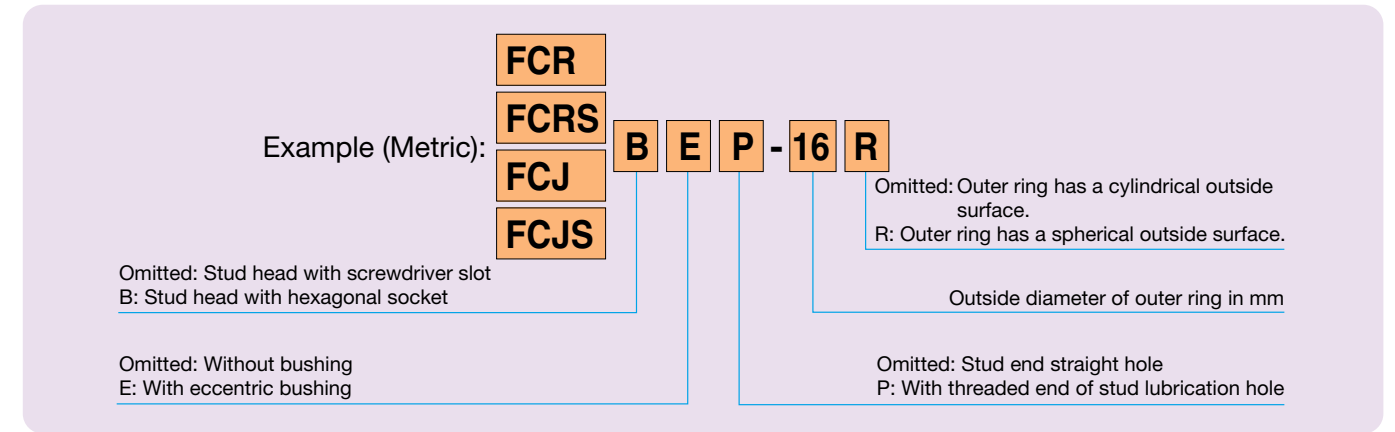

### Example

- FCRE-16** Full complement, with screwdriver slot and eccentric bush. Outside diameter of outer ring is 16 mm.
- FCJSB-16** With cage, seal/thrust washer, and hexagonal socket. Outside diameter of outer ring is 16 mm.
- FCJSP-16** With cage, seal/thrust washer, and threaded end of stud lubrication hole. Outside diameter of outer ring is 16 mm.
- FCRSBE-16R** Full complement, with seal/thrust washer, hexagonal socket, and eccentric bushing. The outer ring has an outside diameter of 16mm and a spherical outside surface.

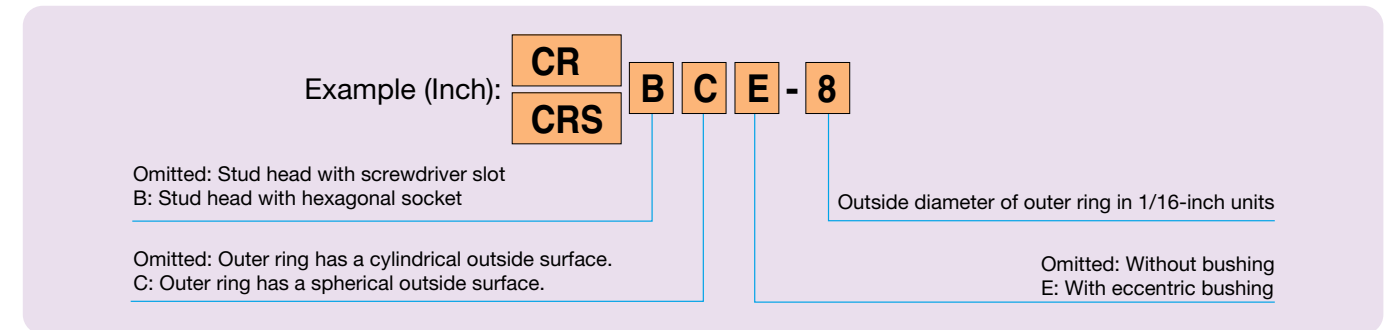

### Example

- CRE-8** Full complement, with screwdriver slot and eccentric bushing. Outside diameter of outer ring is 12.700 mm (8/16 inch).
- CRSB-8** Full complement, with seal/thrust washer and hexagonal socket. Outside diameter of outer ring is 12.700 mm (8/16 inch).
- CRSBCE-8** Full complement, with seal/thrust washer, hexagonal socket, and eccentric bushing. The outer ring has an outside diameter of 12.700 mm (8/16 inch) and a spherical outside surface.

## 4. Spherical Radius of Outer Ring

Spherical radii for metric bearings are shown in Table 2 and for inch bearings in Table 3.

Table 2 Spherical Radius, *R*, of Outer Ring of Metric Bearings Units: mm

All Bearing Numbers	<i>R</i>
	500

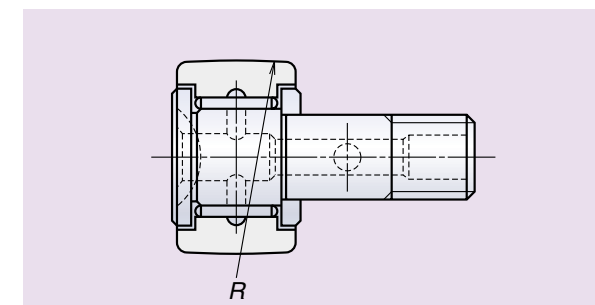

Table 3 Spherical Radius, *R*, of Inch Bearings Units: mm

Bearing Numbers (°)	<i>R</i>	Bearing Numbers (°)	<i>R</i>
CRC-8	150	CRC-28	500
CRC-8-1	180	CRC-30	500
CRC-10	180	CRC-32	600
CRC-10-1	200	CRC-36	600
CRC-12	250	CRC-40	760
CRC-14	250	CRC-44	760
CRC-16	300	CRC-48	760
CRC-18	300	CRC-52	760
CRC-20	360	CRC-56	760
CRC-22	360	CRC-64	760
CRC-24	500	CRC-80	1 200
CRC-26	500	CRC-96	1 400

Note (°) This uses CRC bearings as an example. However, since dimension series are the same, the *R* dimensions shown in the above table should also be applied to CRSC bearings.

## 5. Accuracy

Cam followers are manufactured with the dimensional tolerances shown in Table 4.

Running accuracy is subject to ISO Class 0.

**Table 4 Cam Follower Dimensional Tolerances**

Units:  $\mu\text{m}$

Type		Stud Diameter Deviation, $\Delta d_{mp}$ , or Fitting Tolerance		Single Plane Mean Outside Diameter Deviation, $\Delta D_{mp}$				Deviation of Outer Ring Width, $\Delta C_s$	
				Cylindrical Outside Surface		Spherical Outside Surface			
		high	low	high	low	high	low	high	low
Metric	FCR, FCRS, FCJ, FCJS	h7		According to ISO Class 0		0    - 50		According to ISO Class 0	
Inch	CR, CRS								

## 6. Accessories

Cam followers include a pipe plug, nut, washer, and grease nipple are available as accessories.

When ordering, please add the part code, shown in Table 5, after the bearing number.

**Table 5 Part Code of Accessories**

Type	Pipe Plug	Grease	Nut	Washer	Nipple
FCR, FCJ, CR	Included	Not prepacked	I	N	Z (°)
FCRS, FCJS, CRS	Included	Prepacked			

Note (°) Bearings with threaded end of stud lubrication hole  
 Stud diameter under 12 mm, JIS B1575, A-M6F nipple  
 Stud diameter over 12 mm, JIS B1575, A-PT 1/8 nipple  
 Other than bearings with threaded end of stud lubrication hole  
 Press-fit nipple  
 \* JIS: Japanese Industrial Standard

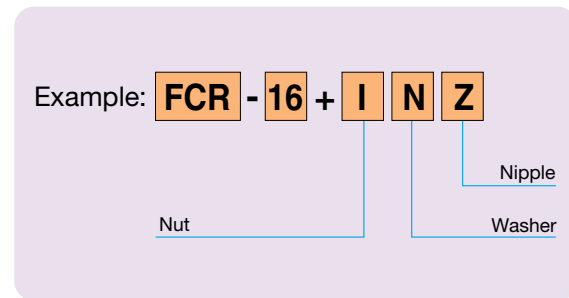

### ● Press-Fit Nipple (Metric)

Units: mm

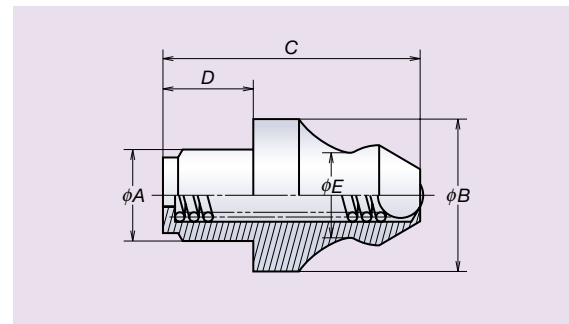

Applicable Bearings	A	B	C	D	E
FCR-16~FCR-26 FCRS-16~FCRS-26	4	8	14	5	5.6
FCR-30~FCR-40 FCRS-30~FCRS-40	6	8	16	6	5.6
FCR-47~FCR-90 FCRS-47~FCRS-90	8	10	18	7	5.6

### ● Press-Fit Nipple (Inch)

Units: mm

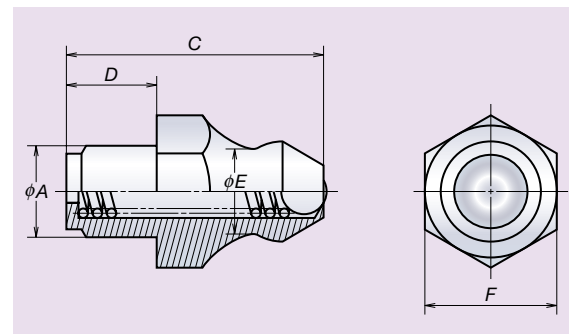

Applicable Bearings	A	C	D	E	F
CR-12~CR-44 CRS-12~CRS-44	4.8	13.5	5	5.6	7
CR-48~CR-96 CRS-48~CRS-96	6.4	15.5	6	5.6	8
CR-8, CR-8-1, CR-10, CR-10-1, CRS-8, CRS-8-1, CRS-10, CRS-10-1	3.2	12.0	4	5.6	7

## 7. Applications to Maximize Performance

### ■ Fitting

The recommended fittings for the mounting area of cam follower studs are shown in Table 6. Since cam followers use cantilever mounting, the fitting for the stud and mounting hole should be assembled with as little play as possible. In case there is interference in the fitting of the stud and mounting hole, the center of the stud end should be inserted with a press. The side plate should be securely fixed onto a plane surface, square to the center axis, without play.

To sufficiently support the side plate, the dimension of the shoulder should be larger than the value of F shown in the bearing table.

### ■ Maximum Permissible Load

The maximum radial load that the cam follower can carry is determined by the bearing strength and shear strength of the stud rather than the load rating for needle bearings. This value is given in the bearing table as the maximum permissible load. The cam follower can deliver maximum

### ■ Permissible Track Load

The permissible load of the track is determined by compression strength or hardness. The permissible load of the track shown in the bearing table is the value of a track made of steel with a hardness of HRC40. Table 7 indicates the permissible load coefficient of the track for each hardness. The permissible load of the track for each hardness can be obtained by multiplying the permissible load of the track shown in the bearing table by the permissible load coefficient of the track corresponding to each hardness.

### ■ Limiting Speed

The cam follower has a bearing with a cage for high speed applications. Its limiting speed is shown in Table 8. Limiting speed for the full-complement bearing type is one-third that

**Table 8 Limiting Speeds for Metric Bearings with Cage**

Bearing Number	Limiting Speed (rpm)	Bearing Number	Limiting Speed (rpm)
FCJB-10	34 000	FCJ-40	5 300
FCJ-12	26 000	FCJ-47	4 800
FCJ-16	16 000	FCJ-52	4 800
FCJ-19	12 000	FCJ-62	3 800
FCJ-22	10 000	FCJ-72	3 800
FCJ-26	10 000	FCJ-80	3 000
FCJ-30	7 500	FCJ-85	3 000
FCJ-32	7 500	FCJ-90	3 000
FCJ-35	6 000		

Play in the mounting part should be avoided because it may not only cause inclination of the stud, but also create considerable deflection when a load is imposed. The load would also be unevenly imposed on the rollers due to edge contact between the outer ring and track (on which the outer ring runs).

**Table 6 Recommended Fitting for Stud Mounting Part**

Type		Fitting Tolerance of Mounting Hole
Metric	FCR, FCJ, FCRS, FCJS	JS7 (J7)
Inch	CR, CRS	F7

strength performance of the stud by mounting securely to the side plate so as to minimize overhang. It is necessary, therefore, to minimize chamfering at the corner of the stud mounting hole and avoid burrs.

**Table 7 Permissible Load Coefficient of Track**

Hardness (HRC)	Coefficient	Hardness (HRC)	Coefficient
20	0.4	45	1.4
25	0.5	50	1.9
30	0.6	55	2.6
35	0.8	58	3.2
40	1.0		

of the cage-bearing type. For grease lubrication, limiting speed will be 60% of each value shown in the table.

### ■ Maximum Clamp Torque

Since the stud of the cam follower receives bending stress and tensile stress from the bearing load, the screw clamp torque should not exceed the value shown in the bearing table. The clamp torque (maximum) in the bearing table is the value when the thread is lubricated, and the value when dry should be approximately doubled.

### ■ Pre-Packed Grease

The cam follower with a seal is pre-lubricated with lithium soap-based grease.

# Cam Followers (Metric design)

- FCR** Full Complement
- FCRS** Full Complement, Sealed with Thrust Washer
- FCJ** With Cage
- FCJS** Sealed, with Cage and Thrust Washer

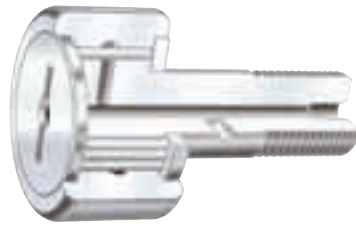

Full Complement

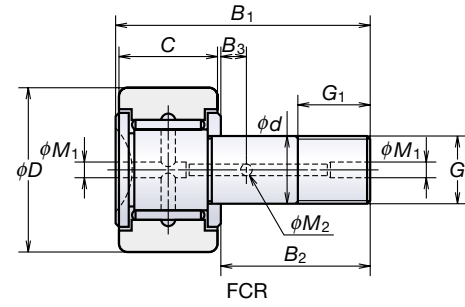

FCR

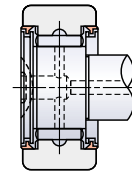

FCRS

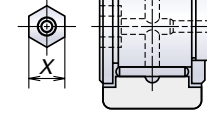

FCRB

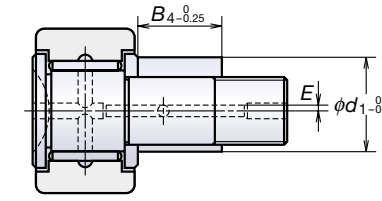

FCRE

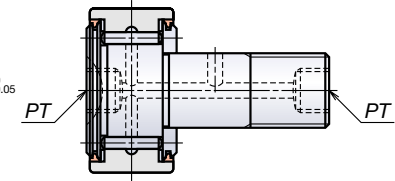

FCRSP

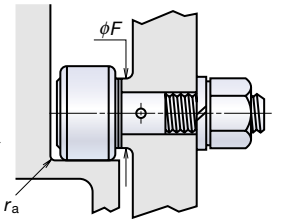

\*1 Dimensions of Hexagonal Socket (width across flats) (°) \*2 Shoulder Dimensions \*3 Fillet Radius of Housing

Bearing Numbers		Boundary Dimensions (mm)			Screw G	Dimensions (mm)						Basic Dynamic Load Ratings (N) Cr	Limiting Loads (N) Pmax	Limiting Track Loads (N)	Mass (kg) Approx.	*1 (mm) X	Eccentric Bushing Dimensions (°)			Threaded Lubrication hole (°) PT	*2 (mm) F min	*3 (mm) ra max	Tightening Torque (°) (N·cm) max
FCR FCJ	FCRS FCJS	D	C	d		G1	B1	B2	B3	M2	M1						B4	d1	E				
FCJB-10	—	10	7	3	M 3x0.5	5	17	9	—	—	—	—	—	—	—	2.5	—	—	—	—	7.5	0.3	28
FCJ-12	—	12	8	4	M 4x0.7	6	20	11	—	—	—	—	—	—	—	—	—	—	—	—	9	0.3	64
FCJB-12	—	12	8	4	M 4x0.7	6	20	11	—	—	—	—	—	—	—	2.5	—	—	—	—	9	0.3	64
FCR-16	FCRS-16	16	11	6	M 6x1.0	8	28	16	—	—	4 (°)	—	—	—	—	4	8	9	0.5	M6x0.75 (°)	11	0.3	226
FCJ-16	FCJS-16	16	11	6	M 6x1.0	8	28	16	—	—	4 (°)	—	—	—	—	4	8	9	0.5	M6x0.75 (°)	11	0.3	226
FCR-19	FCRS-19	19	11	8	M 8x1.25	10	32	20	—	—	4 (°)	—	—	—	—	4	10	11	0.5	M6x0.75 (°)	13	0.3	550
FCJ-19	FCJS-19	19	11	8	M 8x1.25	10	32	20	—	—	4 (°)	—	—	—	—	4	10	11	0.5	M6x0.75 (°)	13	0.3	550
FCR-22	FCRS-22	22	12	10	M10x1.25	12	36	23	—	—	4 (°)	—	—	—	—	5	11	13	0.5	M6x0.75 (°)	15	0.3	1 060
FCJ-22	FCJS-22	22	12	10	M10x1.25	12	36	23	—	—	4 (°)	—	—	—	—	5	11	13	0.5	M6x0.75 (°)	15	0.3	1 060
FCR-26	FCRS-26	26	12	10	M10x1.25	12	36	23	—	—	4 (°)	—	—	—	—	5	11	13	0.5	M6x0.75 (°)	15	0.3	1 060
FCJ-26	FCJS-26	26	12	10	M10x1.25	12	36	23	—	—	4 (°)	—	—	—	—	5	11	13	0.5	M6x0.75 (°)	15	0.3	1 060
FCR-30	FCRS-30	30	14	12	M12x1.5	13	40	25	6	3	6	—	—	—	—	6	12	17	1	M6x0.75 (°)	20	0.6	1 450
FCJ-30	FCJS-30	30	14	12	M12x1.5	13	40	25	6	3	6	—	—	—	—	6	12	17	1	M6x0.75 (°)	20	0.6	1 450
FCR-32	FCRS-32	32	14	12	M12x1.5	13	40	25	6	3	6	—	—	—	—	6	12	17	1	M6x0.75 (°)	20	0.6	1 450
FCJ-32	FCJS-32	32	14	12	M12x1.5	13	40	25	6	3	6	—	—	—	—	6	12	17	1	M6x0.75 (°)	20	0.6	1 450
FCR-35	FCRS-35	35	18	16	M16x1.5	17	52	32.5	8	3	6	—	—	—	—	10	15.5	22	1	RC 1/8	24	0.6	4 000
FCJ-35	FCJS-35	35	18	16	M16x1.5	17	52	32.5	8	3	6	—	—	—	—	10	15.5	22	1	RC 1/8	24	0.6	4 000
FCR-40	FCRS-40	40	20	18	M18x1.5	19	58	36.5	8	3	6	—	—	—	—	10	17.5	24	1	RC 1/8	26	1	5 950
FCJ-40	FCJS-40	40	20	18	M18x1.5	19	58	36.5	8	3	6	—	—	—	—	10	17.5	24	1	RC 1/8	26	1	5 950
FCR-47	FCRS-47	47	24	20	M20x1.5	21	66	40.5	9	4	8	—	—	—	—	12	19.5	27	1	RC 1/8	31	1	8 450
FCJ-47	FCJS-47	47	24	20	M20x1.5	21	66	40.5	9	4	8	—	—	—	—	12	19.5	27	1	RC 1/8	31	1	8 450
FCR-52	FCRS-52	52	24	20	M20x1.5	21	66	40.5	9	4	8	—	—	—	—	12	19.5	27	1	RC 1/8	31	1	8 450
FCJ-52	FCJS-52	52	24	20	M20x1.5	21	66	40.5	9	4	8	—	—	—	—	12	19.5	27	1	RC 1/8	31	1	8 450
FCR-62	FCRS-62	62	29	24	M24x1.5	25	80	49.5	11	4	8	—	—	—	—	14	24.5	34	1	RC 1/8	45	1	15 200
FCJ-62	FCJS-62	62	29	24	M24x1.5	25	80	49.5	11	4	8	—	—	—	—	14	24.5	34	1	RC 1/8	45	1	15 200
FCR-72	FCRS-72	72	29	24	M24x1.5	25	80	49.5	11	4	8	—	—	—	—	14	24.5	34	1	RC 1/8	45	1	15 200
FCJ-72	FCJS-72	72	29	24	M24x1.5	25	80	49.5	11	4	8	—	—	—	—	14	24.5	34	1	RC 1/8	45	1	15 200
FCR-80	FCRS-80	80	35	30	M30x1.5	32	100	63	15	4	8	—	—	—	—	17	31	40	1.5	RC 1/8	52	1	30 500
FCJ-80	FCJS-80	80	35	30	M30x1.5	32	100	63	15	4	8	—	—	—	—	17	31	40	1.5	RC 1/8	52	1	30 500
FCR-85	FCRS-85	85	35	30	M30x1.5	32	100	63	15	4	8	—	—	—	—	17	31	40	1.5	RC 1/8	52	1	30 500
FCJ-85	FCJS-85	85	35	30	M30x1.5	32	100	63	15	4	8	—	—	—	—	17	31	40	1.5	RC 1/8	52	1	30 500
FCR-90	FCRS-90	90	35	30	M30x1.5	32	100	63	15	4	8	—	—	—	—	17	31	40	1.5	RC 1/8	52	1	30 500
FCJ-90	FCJS-90	90	35	30	M30x1.5	32	100	63	15	4	8	—	—	—	—	17	31	40	1.5	RC 1/8	52	1	30 500

Note (°) Only the stud head has a lubrication hole.  
Remarks Standard grease is packed in sealed cam followers, but not in cam followers without seals. Please consult NSK when making a selection.

Notes (°) Applicable to FCRB only. (°) Applicable to FCRE only. (°) Applicable to FCRSP only.  
(°) Only the stud head has a threaded lubrication hole. (°) These values are for when the screw is oiled; they should be approximately doubled when the screw is dry.

- CR** Full Complement
- CRS** Full Complement, Sealed

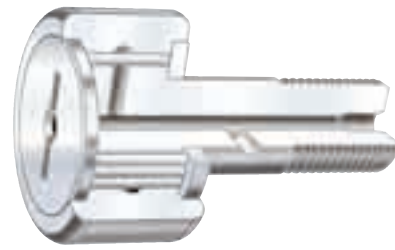

Full Complement

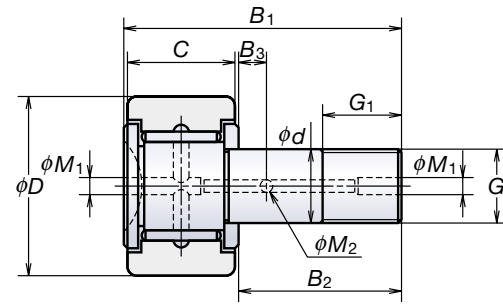

CR

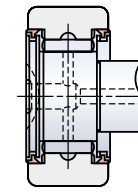

CRS

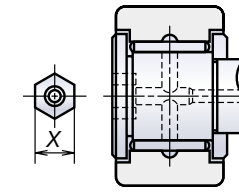

CRB

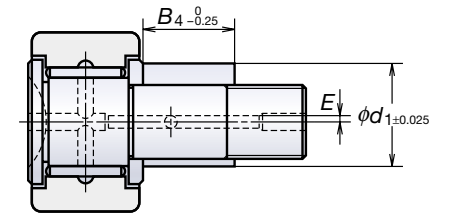

CRE

Bearing Numbers		Boundary Dimensions						Dimensions (mm)						Basic Dynamic Load Ratings (N) $C_r$	Limiting Loads (N) $P_{max}$	Limiting Track Loads (N)	Limiting Speed (*) (rpm)	
CR	CRS	$D$ (mm/inch)		$C$ (mm/inch)		$d$ (mm/inch)		Screw UNF $G$	$G_1$	$B_1$	$B_2$	$B_3$	$M_2$					$M_1$
CR-8	CRS-8	12.700	0.5000	8.74	0.3440	4.826	—	10-32	6.4	22.8	12.70	—	—	3.2 (¶)	3 800	1 340	2 050	7 100
CR-8-1	CRS-8-1			9.52	0.3750	4.826	—	10-32	6.4	26.8	15.88	—	—	3.2 (¶)	4 200	1 340	2 260	7 100
CR-10	CRS-10	15.875	0.6250	10.31	0.4060	6.350	0.2500	1/4-28	7.9	27.3	15.88	—	—	3.2 (¶)	5 350	2 640	2 920	5 600
CR-10-1	CRS-10-1			11.13	0.4380	6.350	0.2500	1/4-28	7.9	31.3	19.05	—	—	3.2 (¶)	5 800	2 640	3 200	5 600
CR-12	CRS-12	19.050	0.7500	12.70	0.5000	9.525	0.3750	3/8-24	9.5	36.1	22.22	6.35	2.4	4.8	8 850	5 900	4 550	3 800
CR-14	CRS-14	22.225	0.8750	12.70	0.5000	9.525	0.3750	3/8-24	9.5	36.1	22.22	6.35	2.4	4.8	8 850	5 900	5 150	3 800
CR-16	CRS-16	25.400	1.0000	15.88	0.6250	11.112	0.4375	7/16-20	12.7	42.4	25.40	6.35	3.2	4.8	11 200	6 950	6 550	3 000
CR-18	CRS-18	28.575	1.1250	15.88	0.6250	11.112	0.4375	7/16-20	12.7	42.4	25.40	6.35	3.2	4.8	11 200	6 950	7 450	3 000
CR-20	CRS-20	31.750	1.2500	19.05	0.7500	12.700	0.5000	1/2-20	15.9	52.2	31.75	7.94	3.2	4.8	18 500	9 600	10 400	2 400
CR-22	CRS-22	34.925	1.3750	19.05	0.7500	12.700	0.5000	1/2-20	15.9	52.2	31.75	7.94	3.2	4.8	18 500	9 600	11 500	2 400
CR-24	CRS-24	38.100	1.5000	22.22	0.8750	15.875	0.6250	5/8-18	19.0	61.6	38.10	9.52	4.0	4.8	21 700	15 900	15 000	2 000
CR-26	CRS-26	41.275	1.6250	22.22	0.8750	15.875	0.6250	5/8-18	19.0	61.6	38.10	9.52	4.0	4.8	21 700	15 900	16 300	2 000
CR-28	CRS-28	44.450	1.7500	25.40	1.0000	19.050	0.7500	3/4-16	22.2	71.2	44.45	11.11	4.0	4.8	27 700	23 600	20 000	1 700
CR-30	CRS-30	47.625	1.8750	25.40	1.0000	19.050	0.7500	3/4-16	22.2	71.2	44.45	11.11	4.0	4.8	27 700	23 600	21 500	1 700
CR-32	CRS-32	50.800	2.0000	31.75	1.2500	22.225	0.8750	7/8-14	25.4	83.9	50.80	12.70	4.8	4.8	41 500	32 500	29 100	1 500
CR-36	CRS-36	57.150	2.2500	31.75	1.2500	22.225	0.8750	7/8-14	25.4	83.9	50.80	12.70	4.8	4.8	41 500	32 500	33 000	1 500
CR-40	CRS-40	63.500	2.5000	38.10	1.5000	25.400	1.0000	1-14 (¶)	28.6	96.9	57.15	14.29	4.8	4.8	52 500	43 000	41 000	1 300
CR-44	CRS-44	69.850	2.7500	38.10	1.5000	25.400	1.0000	1-14 (¶)	28.6	96.9	57.15	14.29	4.8	4.8	52 500	43 000	45 500	1 300
CR-48	CRS-48	76.200	3.0000	44.45	1.7500	31.750	1.2500	1 1/4-12	31.8	109.6	63.50	15.88	4.8	6.4	76 000	67 000	60 000	1 100
CR-52	CRS-52	82.550	3.2500	44.45	1.7500	31.750	1.2500	1 1/4-12	31.8	109.6	63.50	15.88	4.8	6.4	76 000	67 000	64 500	1 100
CR-56	CRS-56	88.900	3.5000	50.80	2.0000	34.925	1.3750	1 3/8-12	34.9	122.3	69.85	17.46	4.8	6.4	99 000	81 500	81 500	950
CR-64	CRS-64	101.600	4.0000	57.15	2.2500	38.100	1.5000	1 1/2-12	38.1	147.7	88.90	19.05	4.8	6.4	126 000	98 000	107 000	900
CRB-80	CRSB-80	127.000	5.0000	69.85	2.7500	50.800	2.0000	2-12 (¶)	65.1	200.9	128.59	22.22	4.8	6.4	198 000	176 000	154 000	600
CRB-96	CRSB-96	152.400	6.0000	82.55	3.2500	63.500	2.5000	2 1/2-12 (¶)	76.2	237.5	152.40	25.40	4.8	6.4	283 000	277 000	226 000	530

- Notes (¶) USN screws are used in place of UNF screws.  
 (¶) UN screws are used in place of UNF screws.  
 (¶) Only the stud head has a lubrication hole.  
 (¶) 60% of this value will be applied for grease lubrication.

Remarks Standard grease is packed in sealed cam followers, but not in cam followers without seals. Please consult NSK when making a selection.

Abutment and fillet dimensions, and tightening torque are shown on the next page.

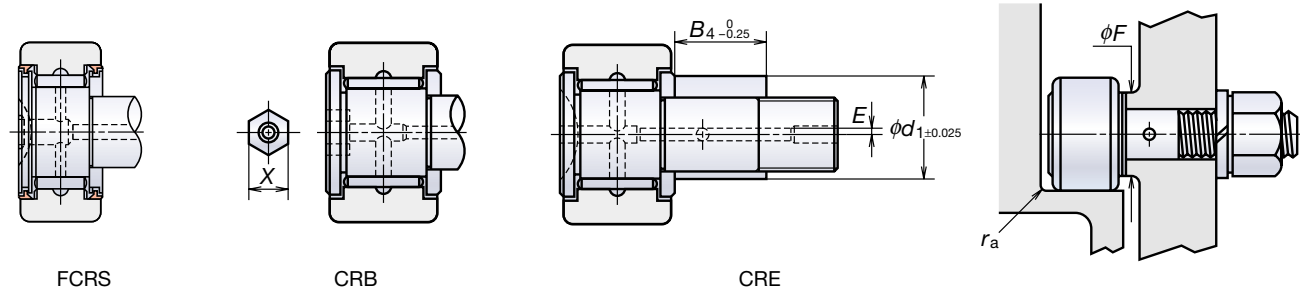

\*1 Dimensions of Hexagonal Socket (width across flats) (°) \*2 Shoulder Dimensions \*3 Fillet Radius of Housing

Bearing Numbers	Mass (kg) Approx.	*1 (mm) X	Eccentric Bushing Dimensions (°) (mm)			*2 (mm) F min	*3 (mm) ra max	Tightening Torque (°) (N·cm) max
			B <sub>4</sub>	d <sub>1</sub>	E			
CR-8	0.010	3.18	—	—	—	7.5	0.25	90
CR-8-1	0.010	3.18	9.52	6.350	0.25	7.5	0.25	90
CR-10	0.019	3.18	—	—	—	9.1	0.4	226
CR-10-1	0.020	3.18	11.10	9.525	0.38	9.1	0.4	226
CR-12	0.034	4.76	12.70	12.700	0.38	12.7	0.4	630
CR-14	0.044	4.76	12.70	12.700	0.38	12.7	0.4	630
CR-16	0.073	6.35	12.70	15.875	0.76	15.1	0.8	1 700
CR-18	0.089	6.35	12.70	15.875	0.76	15.1	0.8	1 700
CR-20	0.135	6.35	15.88	17.450	0.76	19.0	0.8	2 310
CR-22	0.16	6.35	15.88	17.450	0.76	19.0	0.8	2 310
CR-24	0.24	7.94	19.05	22.225	0.76	22.6	0.8	4 400
CR-26	0.275	7.94	19.05	22.225	0.76	22.6	0.8	4 400
CR-28	0.385	7.94	22.22	25.400	0.76	26.6	1	8 500
CR-30	0.43	7.94	22.22	25.400	0.76	26.6	1	8 500
CR-32	0.62	11.11	25.40	30.150	0.76	30.6	1.3	10 200
CR-36	0.755	11.11	25.40	30.150	0.76	30.6	1.3	10 200
CR-40	1.15	12.70	28.58	34.925	0.76	34.9	2.3	15 300
CR-44	1.35	12.70	28.58	34.925	0.76	34.9	2.3	15 300
CR-48	1.9	15.88	31.75	44.450	1.52	44.4	2.3	23 100
CR-52	2.2	15.88	31.75	44.450	1.52	44.4	2.3	23 100
CR-56	2.9	15.88	34.92	46.025	1.52	48.8	2.3	28 200
CR-64	4.3	19.05	50.80	50.800	1.52	57.9	2.3	34 000
CRB-80	8.7	22.22	—	—	—	82.6	4	34 000
CRB-96	15	25.40	—	—	—	99.2	4	34 000

Notes (°) Applicable to CRB only.

(°) Applicable to CRE only.

(°) These values are for when the screw is oiled; they should be approximately doubled when the screw is dry.

## Miniature Cam Follower made of durable, high corrosion-resistant stainless steel ES1

Miniature cam followers are made of durable, high corrosion-resistant stainless steel ES1. These are cam followers with a small diameter and surface area that can be used in various applications and environments where enhanced resistance to corrosion is required.

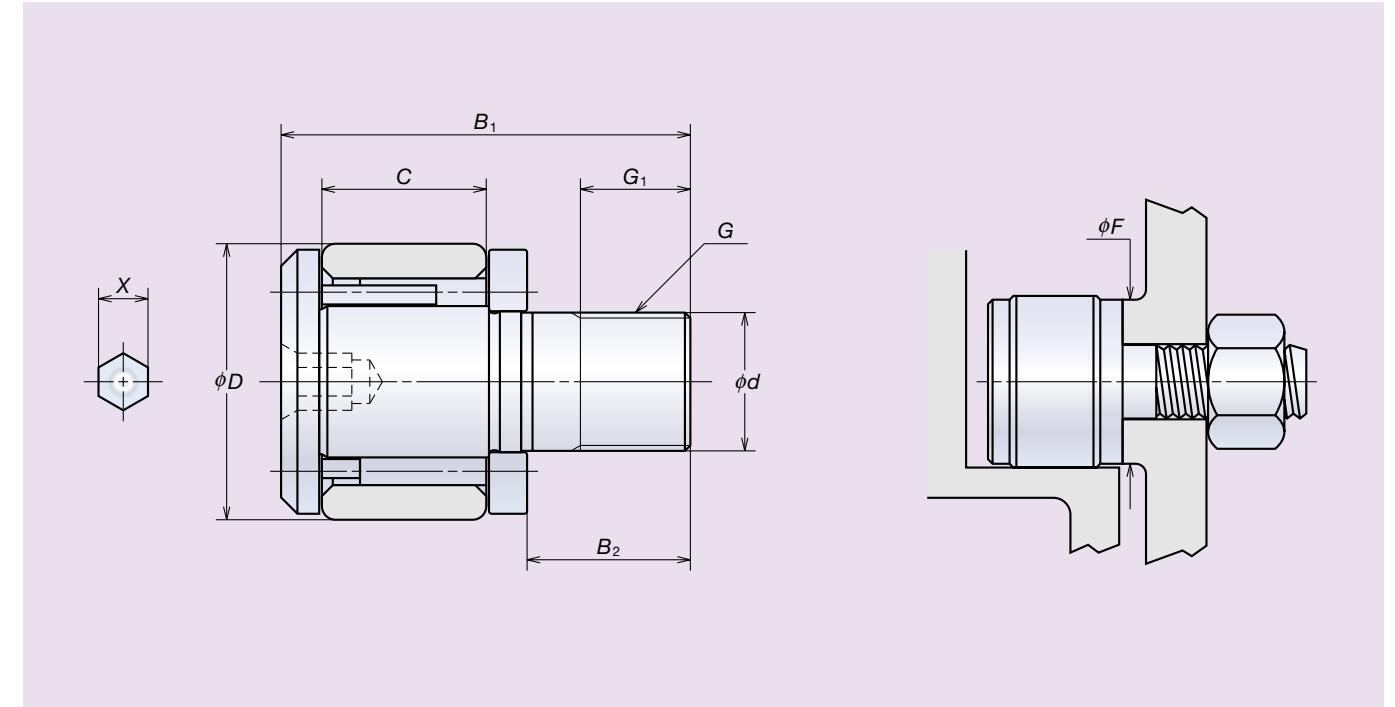

## Standard Specifications for Miniature Cam Followers

Units: mm

Bearing Numbers		D	d	C	B <sub>1</sub>	B <sub>2</sub>	G	G <sub>1</sub>	X	Shoulder Dimensions F (min)	Tightening Torque (N·cm) (max)
With Cage	Full Complement										
FCJMB-5	FCRMB-5	5	2.5	3	9.5	5	M2.5×0.45	2.5	0.9	4.8	16
FCJMB-6	FCRMB-6	6	3	4	11.5	6	M3×0.5	3	1.3	5.8	28
FCJMB-8	FCRMB-8	8	4	5	15	8	M4×0.7	4	1.5	7.7	64
FCJMB-10	FCRMB-10	10	5	6	18	10	M5×0.8	5	2	9.6	125
FCJMB-12	FCRMB-12	12	6	7	21.5	12	M6×1	6	2.5	11.6	226

### FCJMB

Bearing Numbers	Basic Dynamic Load Ratings (N)	
	C <sub>rh</sub>	C <sub>0rh</sub>
FCJMB-5	350	285
FCJMB-6	565	525
FCJMB-8	915	915
FCJMB-10	1 340	1 400
FCJMB-12	1 880	2 040

### FCRMB

Bearing Numbers	Basic Dynamic Load Ratings (N) C <sub>rh</sub>	Limiting Loads (N) P <sub>max</sub>
	FCRMB-5	665
FCRMB-6	1 020	590
FCRMB-8	1 680	1 050
FCRMB-10	2 520	1 640
FCRMB-12	3 400	2 360

Pre-lubricated grease: Lithium soap-based grease is used as lubrication. Accessories: Nut is available as an accessory. Please consult NSK.

The roller follower with a thick-wall outer ring and crowned roller has a large load capacity which enables it to carry shock loads. It is easy to handle because of its non-separating features, and widely used in such applications as track rollers, cams, and rocker arms.

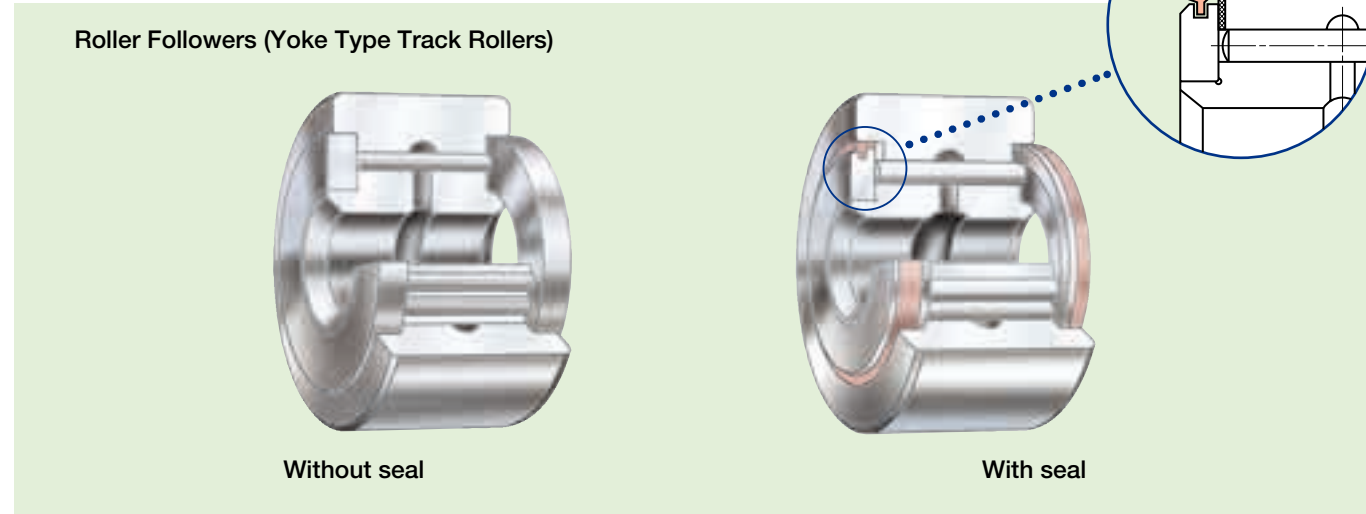

## 1. Types

Roller followers are available in the types shown in Table 1. All of the bearings in Table 1 have a cylindrical outside surface.

Table 1 Bearing Types

Code		Details
Metric	FYCR	Full complement, without seal
	FYCRS	Full complement, with seal and thrust washer
	FYCJ	With cage, without seal
	FYCJS	With cage, seal, and thrust washer
Inch	YCR	Full complement, without seal
	YCRS	Full complement, with seal and thrust washer

Bearings with the following special specifications are available and can be manufactured upon request:

### Special specifications:

#### ■ Outer ring with a spherical exterior

In this case, your order should be placed as follows:

- ① For metric bearings, **R** should be added to the end of the bearing number.  
Example: FYCR-5R, FYCJ-5R, FYCRS-5R, FYCJS-5R
- ② For inch bearings, **C** should be added to the end of the bearing type code.  
Example: YCRC-12, YCRSC-12

Spherical radius of outer ring is shown in Table 4 and 6.

#### ■ Exposed surface treated with a black oxide layer

In addition to the above, products of special shapes and specifications are available and can be manufactured to order. Please contact NSK for further details.

## 2. Accuracy

Metric roller followers are manufactured in compliance with ISO Class 0, and inch followers in compliance with the tolerances shown in Table 2. Running accuracy complies

with ISO Class 0 in both cases. Deviations for the above apply to the bearings before surface treatment.

Table 2 Tolerances for Inch Bearings

Units:  $\mu\text{m}$

Nominal Bore Diameter, $d$ (mm)		Single Plane Mean Bore Diameter Deviation, $\Delta d_{mp}$		Single Plane Mean Outside Diameter Deviation, $\Delta D_{mp}$				Deviation of Outer Ring Width, $\Delta C_S$		Deviation of Overall Inner Ring Width, $\Delta B_S$	
				Cylindrical Outside Surface		Spherical Outside Surface (°)					
over	incl.	high	low	high	low	high	low	high	low	high	low
—	19.05	+5	-10	0	-25	0	-50	0	-130	+130	-250
19.05	57.15	+2	-13	0	-25	0	-50	0	-130	+130	-250

Note (°) Metric bearings have the same dimension tolerance.

## 3. Applications to Maximize Performance

### ■ Fitting

Roller followers are generally used with a transition or loose fit for the shaft because their outer ring rotates. With heavy loads, however, it is recommended to harden the shaft and provide a tight fit. In order to prevent the bearing from moving in the axial direction, both ends of the inner ring should be securely fixed to the plane surface, square to the center axis. To sufficiently support the side plate, the dimension of the shoulder should be larger than the value of  $F$  in the bearing table.

### ■ Permissible Track Load

Permissible track load values are the same as those for cam followers. Please refer to the explanation on permissible track load on page 6.

### ■ Spherical Radius of Outer Ring Outside

Spherical radii for metric bearings are shown in Table 4 and for inch bearings in Table 6.

Table 4 Spherical Radius,  $R$ , of Metric Bearings Outside

Units: mm

All Bearing Numbers	$R$
	500

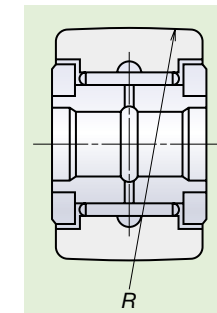

Table 6 Spherical Radius,  $R$ , of Inch Bearing Outside

Units: mm

Bearing Numbers (°)	$R$	Bearing Numbers (°)	$R$
YCRC-12	250	YCRC-32	600
YCRC-14	250	YCRC-36	600
YCRC-16	300	YCRC-40	760
YCRC-18	300	YCRC-44	760
YCRC-20	360	YCRC-48	760
YCRC-22	360	YCRC-52	760
YCRC-24	500	YCRC-56	760
YCRC-26	500	YCRC-64	760
YCRC-28	500	YCRC-80	1 200
YCRC-30	500	YCRC-96	1 400

Note (°) While YCRC bearing numbers are listed here, the values of  $R$  also apply to YCRSC bearings.

Table 3 Recommended Shaft Fittings

Load	Fitting Tolerance of Shaft
Light Load/Normal Load	g6 or h6
Heavy Load	k6

### ■ Pre-Packed Grease

Roller followers with seals are pre-lubricated with lithium soap-based grease.

### ■ Limiting speed

The roller follower has a bearing with a cage for high speed applications. Its limiting speed is shown in Table 5.

Limiting speed for the full-complement bearing type is one-third of the value shown in Table 5. For grease lubrication, limiting speed is 60% of each value shown in the table.

Table 5 Limiting Speed for Metric Bearing with Cage

Bearing Numbers	Limiting Speed (rpm)
FYCJ-5	16 000
FYCJ-6	12 000
FYCJ-8	10 000
FYCJ-10	8 000
FYCJ-12	7 100
FYCJ-15	6 300
FYCJ-17	5 600
FYCJ-20	5 000
FYCJ-25	4 000
FYCJ-30	3 200
FYCJ-35	2 800
FYCJ-40	2 400
FYCJ-45	2 000
FYCJ-50	1 900



# Roller Followers (Metric design)

- FYCR** Full Complement
- FYCRS** Full Complement, Sealed with Thrust Washer
- FYCJ** With Cage
- FYCJS** Sealed, with Cage and Thrust Washer



Full Complement

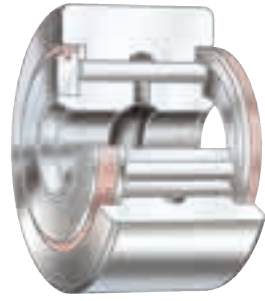

Full Complement, Sealed

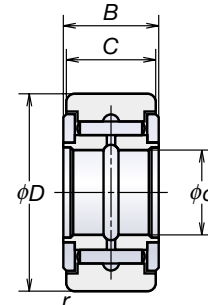

FYCR

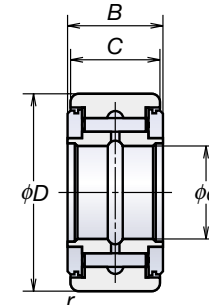

FYCRS

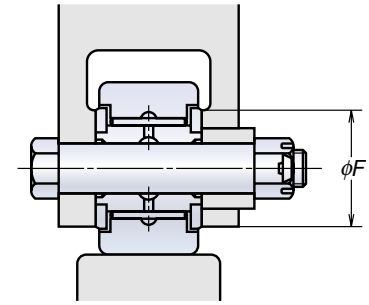

Bearing Numbers		Boundary Dimensions (mm)					Basic Dynamic Load Ratings (N)		Limiting Track Loads (N)	Mass (kg)	Shoulder Dimensions (mm)
FYCR FYCJ	FYCRS FYCJS	<i>d</i>	<i>D</i>	<i>C</i>	<i>B</i> <sub>0 -0.38</sub>	<i>r</i> <sub>min</sub>	<i>C<sub>r</sub></i>	<i>C<sub>or</sub></i>		Approx.	<i>F</i> <sub>min</sub>
FYCR-5	FYCRS-5	5	16	11	12	0.3	5 800	8 000	3 350	0.016	10
FYCJ-5	FYCJS-5	5	16	11	12	0.3	2 830	2 620	3 350	0.014	10
FYCR-6	FYCRS-6	6	19	11	12	0.3	6 550	9 900	4 150	0.022	12
FYCJ-6	FYCJS-6	6	19	11	12	0.3	3 450	3 600	4 150	0.020	12
FYCR-8	FYCRS-8	8	24	14	15	0.3	10 100	15 000	6 500	0.044	14
FYCJ-8	FYCJS-8	8	24	14	15	0.3	5 700	6 000	6 500	0.042	14
FYCR-10	FYCRS-10	10	30	14	15	0.6	11 700	18 500	7 800	0.069	17
FYCJ-10	FYCJS-10	10	30	14	15	0.6	6 950	8 200	7 800	0.067	17
FYCR-12	FYCRS-12	12	32	14	15	0.6	12 600	21 000	8 050	0.076	19
FYCJ-12	FYCJS-12	12	32	14	15	0.6	7 650	9 650	8 050	0.074	19
FYCR-15	FYCRS-15	15	35	18	19	0.6	18 700	29 300	11 800	0.105	23
FYCJ-15	FYCJS-15	15	35	18	19	0.6	12 200	14 100	11 800	0.097	23
FYCR-17	FYCRS-17	17	40	20	21	1	21 100	35 000	14 300	0.145	25
FYCJ-17	FYCJS-17	17	40	20	21	1	13 700	16 700	14 300	0.14	25
FYCR-20	FYCRS-20	20	47	24	25	1	28 900	50 000	20 800	0.255	29
FYCJ-20	FYCJS-20	20	47	24	25	1	18 200	22 600	20 800	0.245	29
FYCR-25	FYCRS-25	25	52	24	25	1	32 500	60 000	22 900	0.285	34
FYCJ-25	FYCJS-25	25	52	24	25	1	22 200	31 000	22 900	0.275	34
FYCR-30	FYCRS-30	30	62	28	29	1	47 500	96 000	33 000	0.48	51
FYCJ-30	FYCJS-30	30	62	28	29	1	31 500	47 000	33 000	0.47	51
FYCR-35	FYCRS-35	35	72	28	29	1	49 500	106 000	36 500	0.64	58
FYCJ-35	FYCJS-35	35	72	28	29	1	33 000	52 500	36 500	0.635	58
FYCR-40	FYCRS-40	40	80	30	32	1	54 500	126 000	43 500	0.88	66
FYCJ-40	FYCJS-40	40	80	30	32	1	38 500	67 500	43 500	0.865	66
FYCR-45	FYCRS-45	45	85	30	32	1	57 500	139 000	46 500	0.93	72
FYCJ-45	FYCJS-45	45	85	30	32	1	40 000	73 000	46 500	0.91	72
FYCR-50	FYCRS-50	50	90	30	32	1	60 500	152 000	49 500	0.995	76
FYCJ-50	FYCJS-50	50	90	30	32	1	41 500	78 000	49 500	0.965	76

Remarks Standard grease is packed in sealed roller followers, but not in roller followers without seals. Please consult NSK when making a selection.

# Roller Followers (Inch)

# Roller Followers

- YCR** Full Complement
- YCRS** Full Complement, Sealed with Thrust Washer



Full Complement

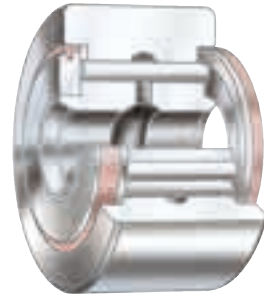

Full Complement, Sealed

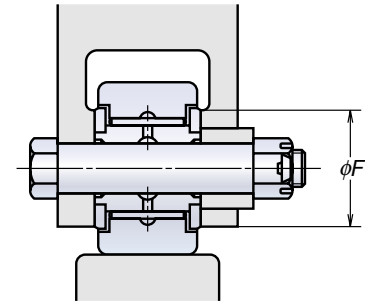
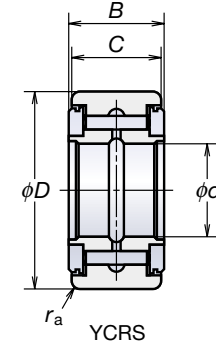
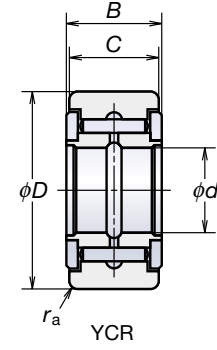

Bearing Numbers		Boundary Dimensions				Basic Dynamic Load Ratings (N)		Limiting Track Loads (N)	Limiting Speed (1) (rpm)	Mass (kg)	Shoulder Dimensions (mm)	Fillet Radius of Housing (mm)			
YCR	YCRS	<i>d</i> (mm/inch)	<i>D</i> (mm/inch)	<i>C</i> (mm/inch)	<i>B</i> (mm)	<i>C<sub>r</sub></i>	<i>C<sub>or</sub></i>			Approx.	<i>F</i> min	<i>r<sub>a</sub></i> max			
YCR-12	YCRS-12	6.350	0.2500	19.050	0.7500	12.70	0.5000	14.29	8 850	14 400	4 550	3 800	0.027	12.7	0.4
YCR-14	YCRS-14	6.350	0.2500	22.225	0.8750	12.70	0.5000	14.29	8 850	14 400	5 150	3 800	0.036	12.7	0.4
YCR-16	YCRS-16	7.938	0.3125	25.400	1.0000	15.88	0.6250	17.46	11 200	20 800	6 550	3 000	0.068	15.1	0.8
YCR-18	YCRS-18	7.938	0.3125	28.575	1.1250	15.88	0.6250	17.46	11 200	20 800	7 450	3 000	0.077	15.1	0.8
YCR-20	YCRS-20	9.525	0.3750	31.750	1.2500	19.05	0.7500	20.64	18 500	32 000	10 400	2 400	0.11	19.0	0.8
YCR-22	YCRS-22	9.525	0.3750	34.925	1.3750	19.05	0.7500	20.64	18 500	32 000	11 500	2 400	0.135	19.0	0.8
YCR-24	YCRS-24	11.112	0.4375	38.100	1.5000	22.22	0.8750	23.81	21 700	42 000	15 000	2 000	0.185	22.6	0.8
YCR-26	YCRS-26	11.112	0.4375	41.275	1.6250	22.22	0.8750	23.81	21 700	42 000	16 300	2 000	0.225	22.6	0.8
YCR-28	YCRS-28	12.700	0.5000	44.450	1.7500	25.40	1.0000	26.99	27 700	60 000	20 000	1 700	0.29	26.6	1.1
YCR-30	YCRS-30	12.700	0.5000	47.625	1.8750	25.40	1.0000	26.99	27 700	60 000	21 500	1 700	0.365	26.6	1.1
YCR-32	YCRS-32	15.875	0.6250	50.800	2.0000	31.75	1.2500	33.34	41 500	85 500	29 100	1 500	0.475	30.6	1.3
YCR-36	YCRS-36	15.875	0.6250	57.150	2.2500	31.75	1.2500	33.34	41 500	85 500	33 000	1 500	0.60	30.6	1.3
YCR-40	YCRS-40	19.050	0.7500	63.500	2.5000	38.10	1.5000	39.69	52 500	118 000	41 000	1 300	0.815	34.9	2.3
YCR-44	YCRS-44	19.050	0.7500	69.850	2.7500	38.10	1.5000	39.69	52 500	118 000	45 500	1 300	1.0	34.9	2.3
YCR-48	YCRS-48	25.400	1.0000	76.200	3.0000	44.45	1.7500	46.04	76 000	172 000	60 000	11 300	1.4	44.4	2.3
YCR-52	YCRS-52	25.400	1.0000	82.550	3.2500	44.45	1.7500	46.04	76 000	172 000	64 500	11 300	1.65	44.4	2.3
YCR-56	YCRS-56	28.575	1.1250	88.900	3.5000	50.80	2.0000	52.39	99 000	228 000	81 500	950	2.25	48.8	2.3
YCR-64	YCRS-64	31.750	1.2500	101.600	4.0000	57.15	2.2500	58.74	126 000	285 000	107 000	900	3.2	57.9	2.3
YCR-80	YCRS-80	44.450	1.7500	127.000	5.0000	69.85	2.7500	73.02	198 000	435 000	154 000	600	6.0	82.6	4.1
YCR-96	YCRS-96	57.150	2.2500	152.400	6.0000	82.55	3.2500	85.72	283 000	645 000	226 000	530	9.95	99.2	4.1

Remarks Standard grease is packed in sealed roller followers, but not in roller followers without seals. Please consult NSK when making a selection.

Note (1) For grease lubrication, limiting speed will be 60% of this value.