



drylin® Stainless Steel



Lubrication-free

Temperature-resistant up to +250°C

Corrosion-resistant

Chemical-resistant

Standard parts with short delivery time

drylin® Stainless Steel

Machine parts made of stainless steel are designed to survive in the worst environments. Heat, pressure, seawater, liquid and gaseous media like detergents and other chemicals. If these machine parts also have to work as a bearing, the combination with iglidur® high-performance polymers is ideal. All bearings are lubricant-free and the plastic parts are secured axially and radially in the housings with positive fit.



The use of **1.4571** and **1.4301** stainless steels mean that the range is resistant to both sea water and aggressive chemicals. Even though these stainless steels are not hardened, they can still be used with igus® bearing materials. In addition, the large surface area of a drylin® bearing helps to keep the surface pressure to a very low level.



Lubrication freedom with drylin® for a baking and conveyor unit.

The suitable iglidur material can be selected according to the application and used for linear and/or rotary motions.

- lubricant-free
- temperature-resistant up to +250 °C
- corrosion-resistant
- resistant to chemicals
- cost-effective

Industries and application areas:

- food and bottling industry
- meat processing
- harbor and crane facilities
- yacht building
- chemical industry
- electroplating industry
- medical and rehabilitation technologies
- packaging industry

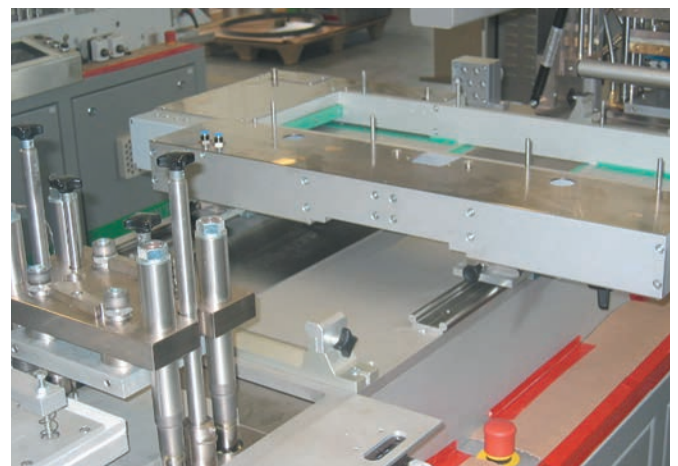

drylin® W is accredited to Cleanroom-standards and therefore used in this blister machine.



drylin® R Linear Plain Bearing | Product Range

Closed stainless steel adapter 1.4305



Order key

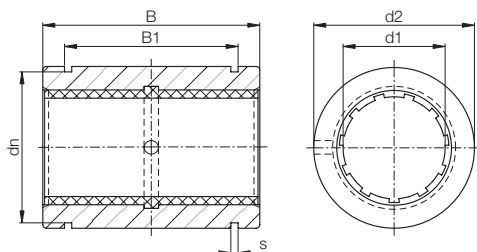

RJUM-01-12-ES

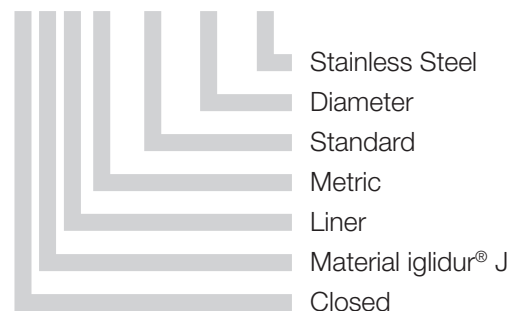

● Dimensions corresp. to the standard for recirculating ball bearings



* according to igus® testing method ► page 925

** design standards ► page 926

Please note: Installation instructions ► page 877

Technical Data

Part number	Shaft Ø [mm]	Tolerance* bearing inner diameter [mm]	F max. dynamic** P = 5 MPa [N]	F max. static** P = 35 MPa [N]	Weight [g]
RJUM-01-12-ES	12	+0.030 +0.088	960	6,720	60
RJUM-01-16-ES	16	+0.030 +0.088	1,440	10,080	84
RJUM-01-20-ES	20	+0.030 +0.091	2,250	15,750	147
RJUM-01-25-ES	25	+0.030 +0.091	3,625	25,375	324
RJUM-01-30-ES	30	+0.040 +0.110	5,100	35,700	486

Dimensions [mm]

Part number	d1	d2 h7	B h10	B1 H10	s H10	dn h10
RJUM-01-12-ES	12	22	32	22.6	1.30	20.5
RJUM-01-16-ES	16	26	36	24.6	1.30	24.2
RJUM-01-20-ES	20	32	45	31.2	1.60	29.6
RJUM-01-25-ES	25	40	58	43.7	1.85	36.5
RJUM-01-30-ES	30	47	68	51.7	1.85	43.5

Also available with liners:



JUM-11



XUM-01

delivery
time

from stock



prices price list online

www.igus.co.uk/en/drylinES

Double rail and housing bearing, round made of stainless steel V4A

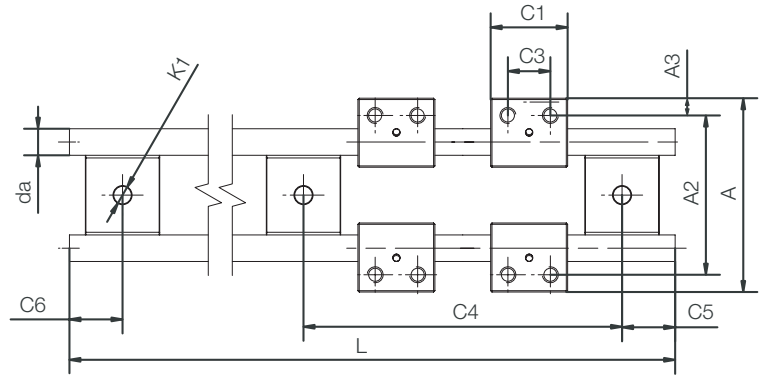
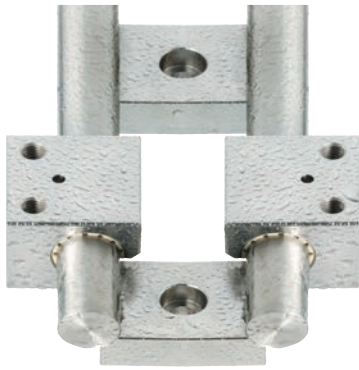

Material for housing and shaft support
Shaft

1.4408
1.4571

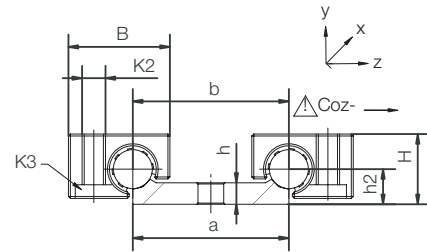

drylin® W Guide Rail, Double, Ø 10 mm – Dimensions [mm]

Part number	Weight [kg/m]	H ±0.07	da h9	L max.	a -0.3	b	h	h2	A	A2
WS-10-40-ES-FG	1.58	18	10	3,000	40	40	5.5	9	73	60

Part number	C4	C5 min.	C5 max.	C6 min.	C6 max.	K1 for Screw DIN 912
WS-10-40-ES-FG	120	20	79.5	20	79.5	M6



drylin® W Housing Bearing – Load Data and Dimensions [mm]

Part number	Weight [g]	B	C1	C3	A3	K2	K3	Stat. Load Capac.		
								Countersunk head screw	Co _y [N]	Co _{z+} [N]
WJUM-01-10-ES-FG*	57	26	29	16	6.5	M6	M5	3,800	3,800	950

* alternative with XUMO-01-10 liners for high temperatures available

Part number: WXUM-01-10-ES-FG



delivery 8–14 days
time



prices price list online
www.igus.co.uk/en/drylinES

drylin® W Modular Guide Systems | Product Range

Single rail and housing bearing, round made of stainless steel V4A

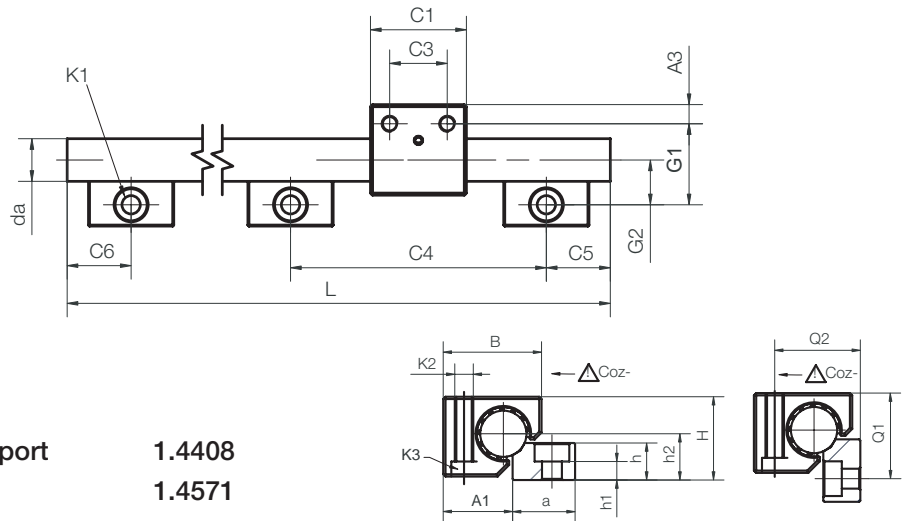

Material for housing and shaft support **1.4408**
Shaft **1.4571**

drylin® W Guide Rail, Single – Dimensions [mm]

Part number	Weight [kg/m]	H* ±0.07	da -0.1	L max.	a -0.3	h	h1	h2	G1	G2	A1	Q1	Q2
WS-10-ES-FG New!	0.87	18	10	3,000	27	5.5	5.5	9	27	17	16.5	-	-
WS-16-ES-FG New!	2.22	27	16	3,000	27	12	4.5	14	33	19	25	32	28
WS-20-ES-FG	3.37	36	20	3,000	27	16	8	20	38	21	30	37	37

Part number	C4	C5 min.	C5 max.	C6 min.	C6 min.	K1 for screw DIN 912	ly [mm²]	lz [mm²]	Wby [mm³]	Wbz [mm³]
WS-10-ES-FG New!	120	20	79.5	20	79.5	M6**	491	491	98	98
WS-16-ES-FG New!	120	20	79.5	20	79.5	M8	3,217	3,217	402	402
WS-20-ES-FG	120	20	79.5	20	79.5	M8	7,854	7,854	785	785

* Height dimension minus the bearing clearance tolerance ** Through bore-hole



drylin® W Housing Bearing – Load Data and Dimensions [mm]

Part number	Weight [g]	B	C1	C3	A3	K2	K3 Countersunk head screw	Stat. Load Capac.		
								Coy [N]	Coz+ [N]	Coz- [N]
WJUM-01-10-ES-FG* New!	57	26	29	16	6.5	M6	M5	3,800	3,800	950
WJUM-01-16-ES-FG New!	134	34.5	36	18	9	M8	M6	6,900	6,900	1,450
WJUM-01-20-ES-FG**	280	42.5	45	27	9	M8	M6	11,000	11,000	1,900

* alternative with XUMO-01-10 liners for high temperatures available, Part number: WXUM-01-10-ES-FG

** alternative with XUMO-01-20 liners for high temperatures available, Part number: WXUM-01-20-ES-FG

Stainless Steel Shafts



EWM-06-...



Length

Outer-Ø

Metric

Material: stainless steel

EWM – 1.4125

EEWM – 1.4034

EWMR – 1.4301

EWMS – 1.4571

- Available shaft materials:
 - Stainless steel (1.4125), hardened/ground
 - Stainless steel (1.4034), hardened/ground
 - Stainless steel (1.4301 oder 1.4571), drawn
 - Stainless steel (1.4112), hardened/ground
- Even totally supported with standard aluminum support
- For supported shafts:
 - ▶ Shaft support supplied in lengths of 600 mm max.
 - ▶ Two hole pitches are available, T2 (standard) or T1
 - ▶ Hole pitches symmetrical C5 = C6



Dimensions [mm] – Hardened Stainless Steel 1.4125

Part number	d	Weight [kg/m]	Max. length	Effective hardness depth (at 1.4125)
EWM-06*	06	0.222	3,000	0.8
EWM-08*	08	0.359	4,000	0.9
EWM-10*	10	0.617	4,000	0.9
EWM-12	12	0.888	6,000	1.0
EWM-16	16	1.578	6,000	1.2
EWM-20	20	2.466	6,000	1.6
EWM-25	25	3.853	6,000	1.8
EWM-30	30	5.549	6,000	2.0
EWM-40	40	9.865	6,000	2.2
EWM-50	50	15.413	6,000	2.4

* Material X90 (1.4112)



delivery 3–8 days
time



prices price list online
www.igus.co.uk/en/drylinES

drylin® Shafts | Product Range

Stainless Steel Shafts

Dimensions [mm] – Hardened Stainless Steel 1.4034

Part number	d	Weight [kg/m]	Max. length	Effective hardness depth (at 1.4034)
EEWM-06	06	0.222	3,000	0.8
EEWM-08	08	0.359	4,000	0.9
EEWM-10	10	0.617	4,000	0.9
EEWM-12	12	0.888	6,000	1.0
EEWM-16	16	1.578	6,000	1.2
EEWM-20	20	2.466	6,000	1.6
EEWM-25	25	3.853	6,000	1.8
EEWM-30	30	5.549	6,000	2.0
EEWM-40	40	9.865	6,000	2.2
EEWM-50	50	15.413	6,000	2.4



Dimensions [mm] – Stainless Steel 1.4301 (EWMR) or 1.4571 Soft Stainless Steel (EWMS)

Part number	d	Weight [kg/m]	Max. length
EWMR-10	10	0.617	4,000
EWMS-10	10	0.617	4,000
EWMR-12	12	0.888	6,000
EWMR-16	16	1.578	6,000
EWMR-20	20	2.466	3,000
EWMS-20	20	2.466	6,000
EWMR-25	25	3.853	6,000
EWMR-30	30	5.549	6,000

Order example: EWM-16-500 corresponds to a stainless steel shaft 16 mm Ø 1.4125, 500 mm in length.



delivery 3–8 days
time



prices price list online
www.igus.co.uk/en/drylinES

Supported Stainless Steel Shafts

EWUM

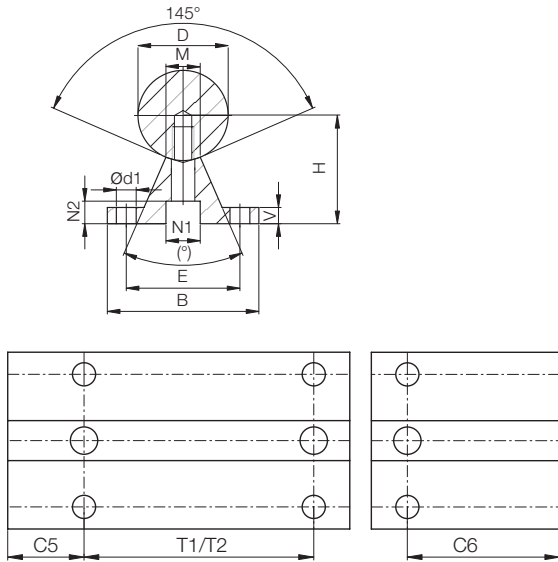

EWUMN

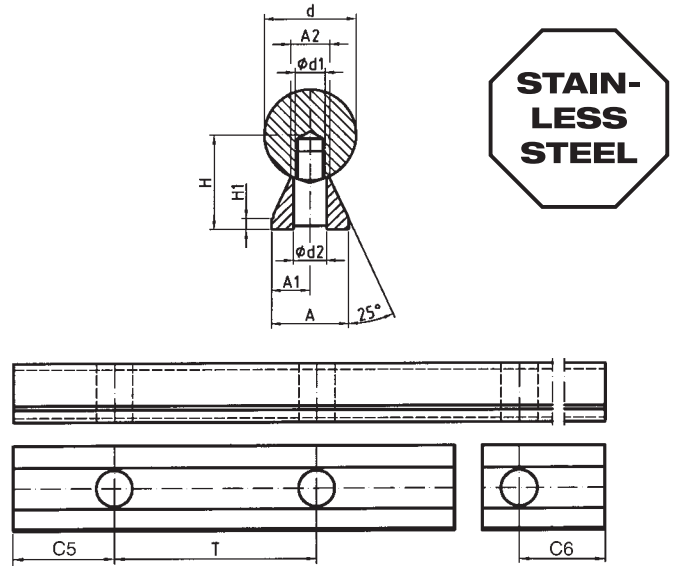

Dimensions [mm] – Supported Stainless Steel Shafts 1.4125

Part number	D	B	H	V	N1	N2	d1	M	(°)	E	T1*	C5/C6		T2	C5/C6		Weight [kg/m]
												min.	max.		min.	max.	
			±0.02								±0.15	for T1	Standard	Standard			
EWUM-12	12	40	22	5	8.0	5.0	4.5	5.8	50	29	75	20	57	120	20	79	1.75
EWUM-16	16	45	26	5	9.5	6.0	5.5	7.0	50	33	100	20	69	150	20	94	2.64
EWUM-20	20	52	32	6	11.0	6.5	6.6	8.3	50	37	100	20	69	150	20	94	3.97
EWUM-25	25	57	36	6	14.0	8.5	6.6	10.8	50	42	120	20	79	200	20	119	5.65
EWUM-30	30	69	42	7	17.0	10.5	9.0	11.0	50	51	150	20	94	200	20	119	7.93
EWUM-40	40	73	50	8	17.0	10.5	9.0	15.0	50	55	200	20	119	300	20	169	12.88
EWUM-50	50	84	60	9	19.0	12.5	11.0	19.0	46	63	200	20	119	300	20	169	19.60

* Two hole pitches are available, T2 (standard) or T1

Dimensions [mm] – Low Level Supported Stainless Steel Shafts 1.4125

Part number	d	H	H1	A	A1	A2	d1	d2	T	C5/C6		Weight [kg/m]
										min.	max.	
		±0.02				±0.02						
EWUMN-12	12	14.5	3	11	5.5	5.4	M4	4.5	75	20	57	1.62
EWUMN-16	16	18	3	14	7.0	7.0	M5	5.5	75	20	57	2.54
EWUMN-20	20	22	3	17	8.5	8.1	M6	6.6	75	20	57	3.81
EWUMN-25	25	26	3	21	10.5	10.3	M8	9.0	75	20	57	5.62
EWUMN-30	30	30	3	23	11.5	11.0	M10	11.0	100	20	69.5	7.63
EWUMN-40	40	39	4	30	15.0	15.0	M12	13.5	100	20	69.5	13.47
EWUMN-50	50	46	5	35	17.5	19.0	M14	15.5	100	20	69.5	20.31

Low level supported shafts are delivered unmounted.

Order example: EWUMN-16-500 corresponds to a low level supported stainless steel shaft (1.4125) 16 mm Ø, 500 mm in length.



delivery 3–8 days
time



prices price list online
www.igus.co.uk/en/drylinES

drylin® Shafts | Product Range

Partially supported stainless steel shafts



Order key

EWUM-ES-20-...

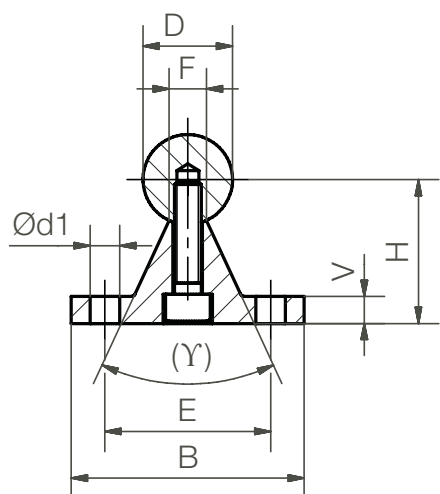
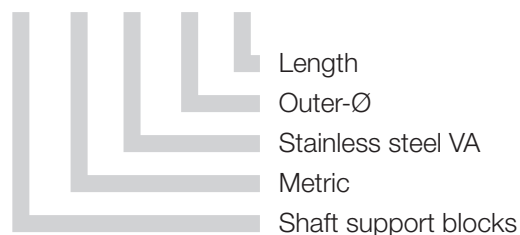

Shaft support blocks for Ø 20 mm made of stainless steel VA

- Connecting dimensions as standard shaft supports in aluminum
- High corrosion and chemical resistance
- Best addition for stainless steel shafts
- Available stainless steel shafts in 1.4571 and 1.4125
- Possible lengths:
 - EWUM (1.4125) max. 6,000 mm
 - EWUMS (1.4571) max. 3,000 mm

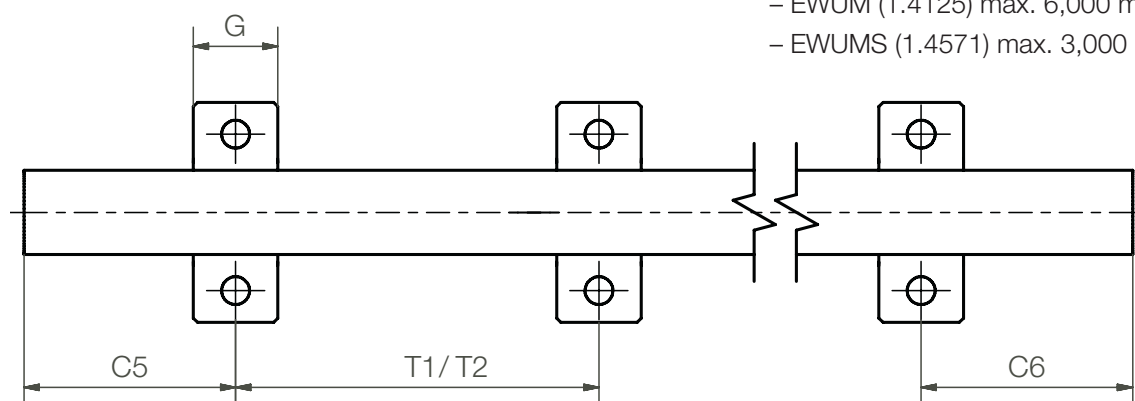

Dimensions [mm]

Part number	Shaft material	D h6	B	H ±0.02	V	d1	E	Y	F	G	T1	C5/C6 for T1		T2	C5/C6 for T2	
												min.	max.		min.	max.
EWUM-ES-20	1.4125	20	52	32	6	6.6	37	50°	8.3	20	100	20	69	150	20	94
EWUMS-ES-20	1.4571	20	52	32	6	6.6	37	50°	8.3	20	100	20	69	150	20	94



delivery time 3–8 days



prices price list online
www.igus.co.uk/en/drylinES

SHTC-HYD – Hygienic design

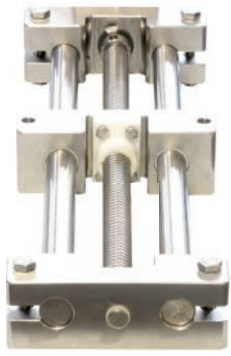

Order key
complete ▶ page 1033

SHTC-20-EWM-HYD

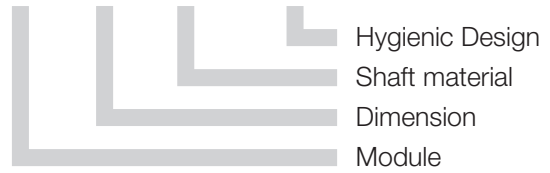

Based on the “hygienic design” idea, this version offers an easily cleaned solution. The screw connections are raised with no dirt traps, and any gaps are intentionally wide. The materials used are plastic and VA stainless steel.

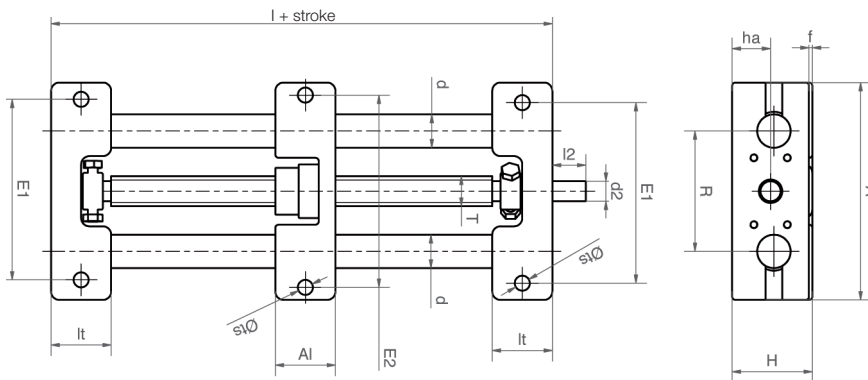

The lead screw unit can be supplied completely with FDA-approved materials.

Dimensions [mm]

Part number	A	Al	H	E1	E2	I	R	f	lt	ts	d	T	l2	d2	ha
	-0.3	-0.3		±0.15	±0.15										
SHTC-20-EWM-HYD	130	35	48	108	115	108	72	2	36	9.0	20	TR 18 x 4	26	12 h9	23

Available accessories ▶ page 1065

Assembly in combination with following bearing materials:



iglidur® J
Standard up to +90 °C



iglidur® X
for temperatures up to +250 °C
High chemical resistance



iglidur® A180
for applications with food contact (FDA)



delivery from stock
time



prices price list online
www.igus.co.uk/en/drylinES

drylin® SLW | Delivery Program | Trapezoidal Thread

SLW-ES – Stainless steel



- Stainless steel version with corrosion-resistant steel components (1.4305, 1.4408 or 1.4571)
- Choice of bearing material:
iglidur® J = Standard
iglidur® A180 = FDA
iglidur® X = High temperature
- Available accessories
▶ page 1065



Order key
complete ▶ page 1046

SLW-ESJ-1040

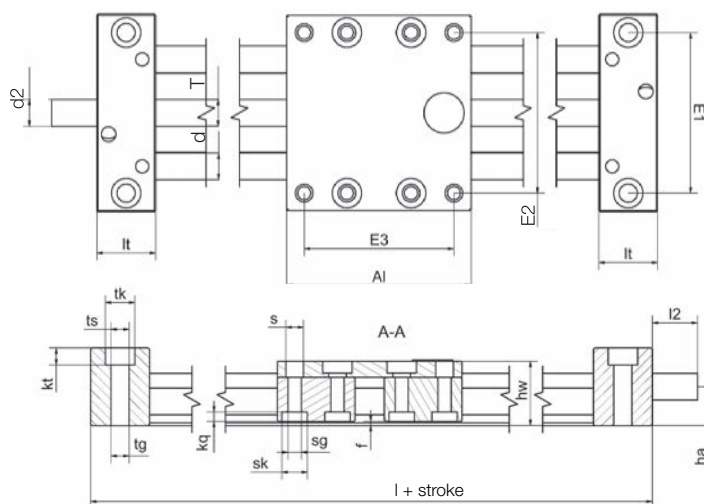
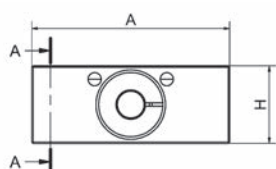
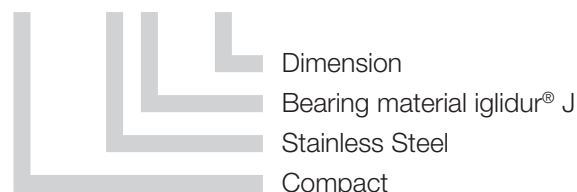

Technical Data

Part number	Shaft-Ø	Max. stroke length	Weight	Additional (per 100 mm)	Max. static load capacity	
	[mm]				[kg]	axial [N]
SLW-ESJ-1040	10	750	1.4	0.2	700	2,800
SLW-ESX-1040	10	750	1.4	0.2	700	2,800
SLW-ESA180-1040	10	750	1.4	0.2	700	2,800
SLW-ESJ-2080	20	1,000	5.7	0.64	1,600	6,400
SLW-ESA180-2080	20	1,000	5.7	0.64	1,600	6,400

Dimensions [mm]

Part number	A	Al	H	E1	E2	E3	I	hw	f	lt	tk	ts	tg
	-0.3	-0.3		±0.15	±0.15	±0.15				±0.1			
SLW-ES-1040	74	100	29	60	60	87	144	24	1.5	22	11	6.8	M8
SLW-ES-2080	134	150	46	116	116	132	206	44	1.5	28	15	8.6	M10

Part number	kt	s	sk	sg	kq	d	T	l2	d2	ha
	±0.1								Standard	
SLW-ES-1040	6.4	6.6	9.5	M6	4.4	10	TR10x2	17	TR10x2*	14.5
SLW-ES-2080	8.6	9.0	14	M8	5.5	20	TR18x4	26	12h9	23.0

* lead screw end unmachined



delivery 8–14 days
time



prices price list online
www.igus.co.uk/en/drylinES

SLW – compact XY-table – stainless steel

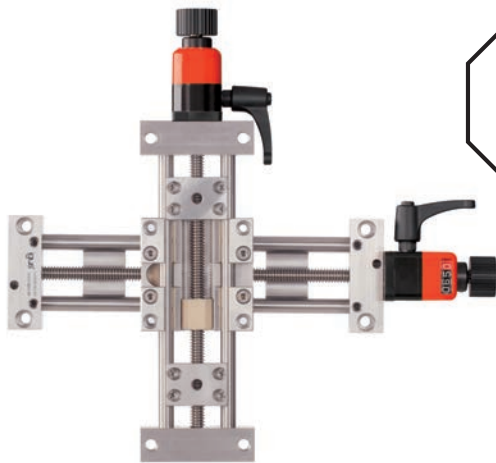

- For manual adjustments
- Flat and compact
- High torsional stability stiffness
- Complete design with stainless steel 316
- 100 % lubrication-free
- Chemical- and corrosion-resistant
- Available accessories ► **page 1065**

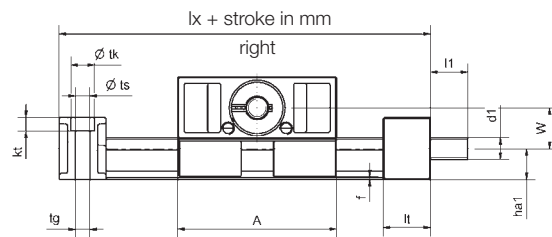
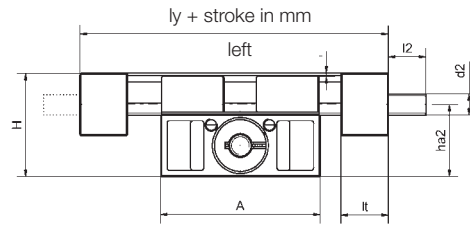
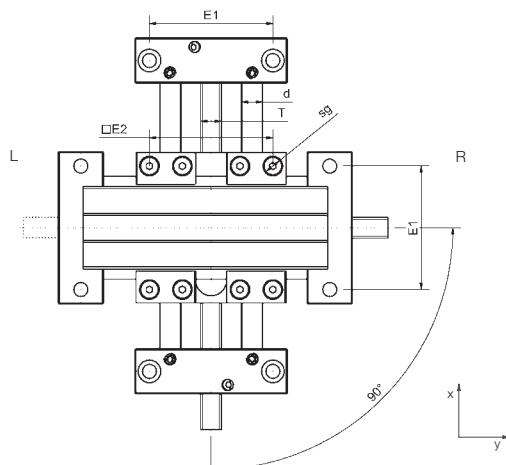

Dimensions [mm]

Part number	A	H	E1	E2	Base length	Base length	f	lt	tk	ts	tg	kt
	-0.3		±0.15	±0.15	lx	ly			±0.1			
SLW-XY-ESJ-1040	74	48	60	60	118	118	1.5	22	11	6.6	M8	6.4

Dimensions [mm]

Part number	sg	d	T	l1	d1		l2	d2		ha1	ha2	W ha2- ha1
					Standard	Alternative		Standard	Alternative			
SLW-XY-ESJ-1040	M6	10	TR 10 x 2	17	TR 10 x 2	6 h9	17	TR 10 x 2	6 h9	14.5	33.5	19

The hand wheel on the y-axis can be ordered fitted to the left or the right side.

Left: SHT-XY-ESJ-1040-AWM-L-200-300 for 200 mm stroke length on the x-axis and 300 mm on the y-axis

Right: SHT-XY-ESJ-1040-AWM-R-200-300 for 200 mm stroke length on the x-axis and 300 mm on the y-axis



delivery 8–14 days
time



prices price list online
www.igus.co.uk/en/drylinES