



## **Four-row linear recirculating ball bearing and guideway assembly**

**Full complement  
For high speed applications**

# Four-row linear recirculating ball bearing and guideway assembly

	Page
<b>Product overview</b>	
Four-row linear recirculating ball bearing and guideway assembly .....	2
<b>Features</b>	
High-Speed for highly dynamic requirements.....	3
Standard version .....	3
X-life .....	3
Preload.....	4
Sealing and lubrication.....	4
Operating temperature .....	4
Further information.....	4
<b>Design and safety guidelines</b>	
Demands on the adjacent construction.....	5
Geometrical and positional accuracy of the mounting surfaces..	5
<b>Accuracy</b>	
.....	5
<b>Dimension tables</b>	
Four-row linear recirculating ball bearing and guideway assembly, full complement, High-Speed .....	6
Guideway for profiled sections.....	10
Clamping lug, clamping strip .....	11

# Product overview **Four-row linear recirculating ball bearing and guideway assembly**

**Full complement**  
High-Speed variant

**KUVE..-B-HS**

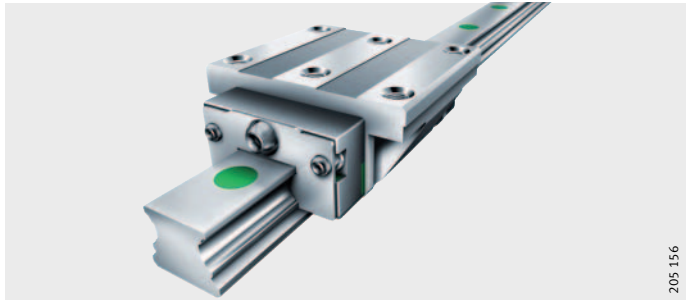

**Guideways**

**TKVD**

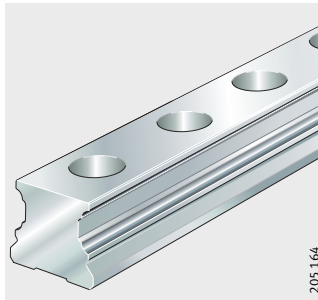

**TKVD..-U**

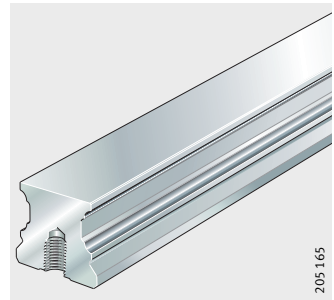

**TKVD..-K**

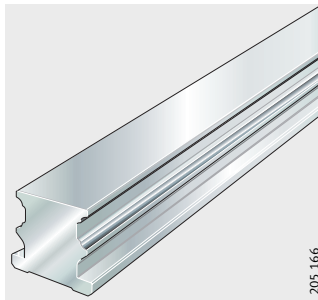

**Standard accessories**  
Dummy guideways  
Plastic closing plugs

**MKVD**



**KA..-TN/A**

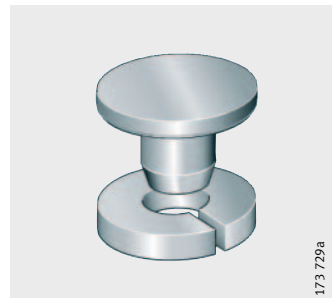

# Four-row linear recirculating ball bearing and guideway assembly

## Features

### High-Speed for highly dynamic requirements

The new four-row linear recirculating ball bearing and guideway assembly KUVE...-B-HS, the High-Speed variant, represents a further expansion of the existing extensive KUVE range in the field of highly dynamic applications.

This variant is extremely robust and is currently the fastest four-row linear recirculating ball bearing and guideway assembly on the market. Depending on the operating conditions, speeds up to 10 m/s are possible.

### A combination of new and proven components

In order to achieve these values, the end piece and ball return system were redesigned. As a result, the total length of the carriage is slightly longer than the standard version. The design envelope corresponds, as before, to DIN 645-1. The loads are still supported by standard steel rolling elements. Since we have continued to adhere strictly to the modular concept with this new development, the new generation of guidance systems is of course interchangeable with the comparable KUVE-B units.

The new unit will be used where there are very high dynamic requirements. Since hybrid technology has not been used in this case, the full performance capacity of the rolling contact can be implemented, with the associated advantages in terms of load carrying capacity, rigidity, robustness and crash safety.

The system is being introduced in the size 25 commonly used in many applications.

### Standard version

The new series comprises at least one carriage, a guideway and dummy guideway as well as two-piece plastic closing plugs. It is supplied as a unit or separately as a carriage and guideway. In a unit, one or more carriages are mounted on a guideway. The carriages have an initial greasing.

A lubrication nipple for fitting in the end face is supplied loose with the delivery.

The carriages have saddle plates with hardened and precision ground rolling element raceways. The guideways are made from hardened steel and are ground on all faces, the rolling element raceways are precision ground.

### X-life

The linear recirculating ball bearing and guideway assemblies are supplied in X-life quality. These bearings are characterised by improved technological features, increased robustness and longer operating life.

# Four-row linear recirculating ball bearing and guideway assembly

**Preload** The units are available in preload class V1 and V2.  
The preload in V1 is 0,04 C, the preload in V2 is 0,1 C.

**Sealing and lubrication** Due to the integrated lubricant reservoir, the units have longer relubrication intervals. Depending on the application, they may also give maintenance-free operation.  
The carriage has elastic wipers on both sides that prevent the ingress of contamination. In addition, lower sealing strips ensure effective sealing. These sealing elements protect the rolling element system from contamination even under demanding environmental conditions.

**Operating temperature** Operating temperatures from  $-10\text{ }^{\circ}\text{C}$  to  $+100\text{ }^{\circ}\text{C}$  are possible.

## Further information

**Caution!** In order to ensure optimum lubricant distribution, we recommend that the carriages should be moved several times at low speed before initial operation and after maintenance and lubrication intervals.  
In relation to load carrying capacity and life, design of bearing arrangements, guideway hole patterns, fitting and operation of the guidance systems, the data given in Market Information MAI 91 and Catalogue 605, Monorail Guidance Systems must be observed.

## Design and safety guidelines

### Demands on the adjacent construction

The running accuracy is essentially dependent on the straightness, accuracy and rigidity of the fit and mounting surfaces. The straightness of the system is only achieved when the guideway is pressed against the datum surface.

If high demands are to be made on the running accuracy and/or if soft substructures and/or movable guideways are used, please contact us.

### Geometrical and positional accuracy of the mounting surfaces

The higher the requirements for accuracy and smooth running of the guidance system, the more attention must be paid to the geometrical and positional accuracy.

### Accuracy

The guideways are available with parallelism tolerances in the accuracy classes G1 to G4. The standard is G3, *Figure 1*.

- ① Parallelism tolerance
  - ② Total guideway length
- t is derived from differential measurement

*Figure 1*  
Accuracy classes and parallelism tolerances

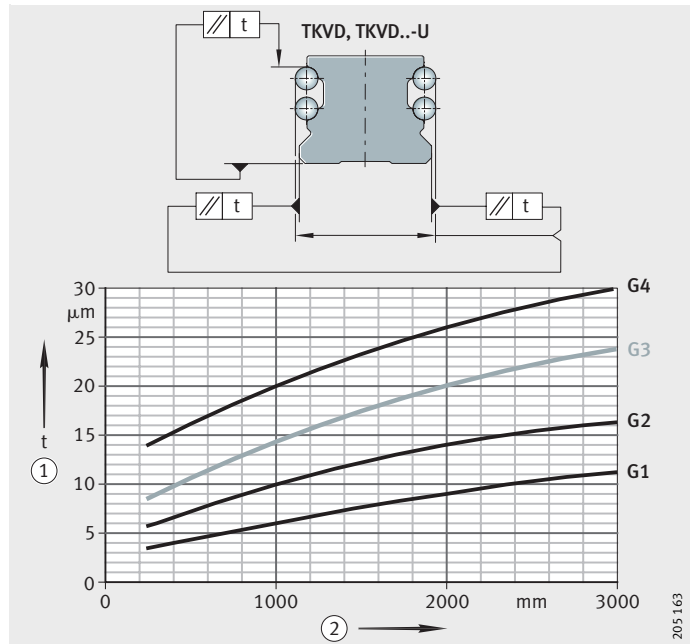

# Four-row linear recirculating ball bearing and guideway assembly

Full complement  
High-Speed

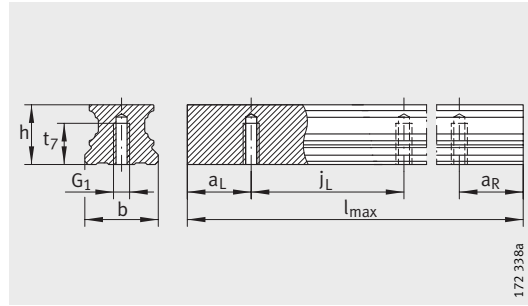

TKVD...U

172 338a

**Dimension table** - Dimensions in mm

Designation	Dimensions				Mounting dimensions											
	$l_{max}^{1)}$	H	B	L	$A_1$	$J_B$	b	$A_2$	$L_1$	$J_L$	$J_{LZ}$	$j_L$	$a_L/a_R^{2)}$		$H_1$	$H_4$
													min.	max.		
<b>KUVE25-B-HS</b>	2 960	36	70	89,3	23,5	57	23	6,5	60,7	45	40	60	20	53	5,1	10,9
<b>KUVE25-B-HS-N</b>	2 960	31	70	89,3	23,5	57	23	6,5	60,7	45	40	60	20	53	5,1	9,3

- 1) Maximum length of single piece guideways.  
Permissible guideway length by agreement. Max. single piece guideway length of 6 m by agreement.
- 2)  $a_L$  and  $a_R$  are dependent on the guideway length.
- 3) If there is a possibility of preload loss due to settling, the fixing screws should be secured against rotation.
- 4) Lubrication nipple with tapered head to DIN 71 412-B M6 supplied loose.

**Dimension table** (continued) - Dimensions in mm

Designation	Carriage		Guideway			Load carrying capacity <sup>1)</sup>				
	Designation	Mass m ≈kg	Designation	Mass m ≈kg	Closing plug $K_2$	Basic load ratings		Moment ratings		
						dyn. C N	stat. $C_0$ N	$M_{0x}$ Nm	$M_{0y}$ Nm	$M_{0z}$ Nm
<b>KUVE25-B-HS</b>	KWVE25-B-HS	0,71	TKVD25(-U)	2,7	KA11-TN/A	17 900	37 000	510	395	395
<b>KUVE25-B-HS-N</b>	KWVE25-B-HS-N	0,57	TKVD25(-U)	2,7	KA11-TN/A	17 900	37 000	510	395	395

- 1) Calculation of basic load rating according to DIN 636.  
Increased basic dynamic load rating possible on the basis of practical experience.

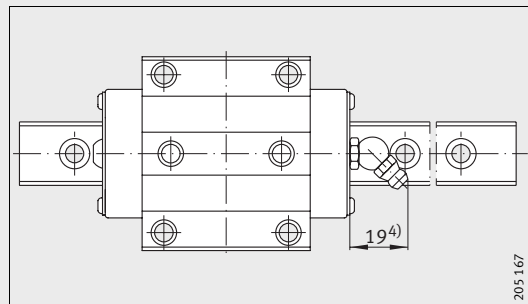

KUVE25-B-HS..

205 167

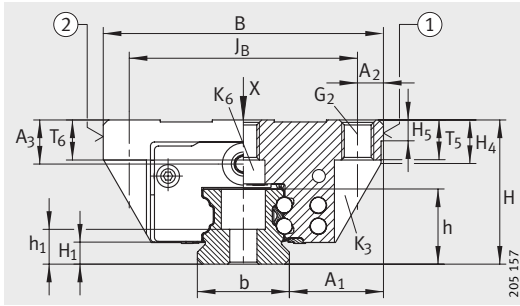

KUV25-B-HS

① Locating face, ② Marking

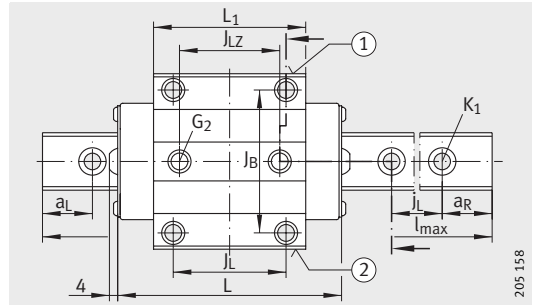

KUV25-B-HS · View X (rotated 90°)

① Locating face, ② Marking

H <sub>5</sub>	A <sub>3</sub>	T <sub>5</sub>	T <sub>6</sub>	t <sub>7</sub>	h	h <sub>1</sub>	Fixing screws <sup>3)</sup>											
							G <sub>1</sub>		G <sub>2</sub>		K <sub>1</sub>		K <sub>3</sub>		K <sub>6</sub>		K <sub>6</sub>	
							DIN ISO 4762-12.9		DIN ISO 4762-12.9		DIN ISO 4762-12.9		DIN ISO 4762-12.9		DIN 7984-8.8		DIN 7984-8.8	
							Nm	Nm	Nm	Nm	Nm	Nm	Nm	Nm	Nm	Nm		
5	11	10	10	12	18,7	8,7	M6	17	M8	24	M6	17	M6	17	M6	17	-	-
5	6	10	8	12	18,7	8,7	M6	17	M8	24	M6	17	M6	17	-	-	M6	8

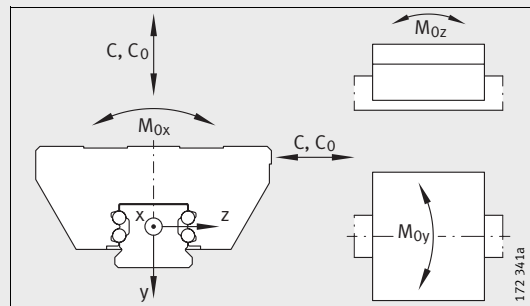

Load directions



# Four-row linear recirculating ball bearing and guideway assembly

Full complement  
High-Speed

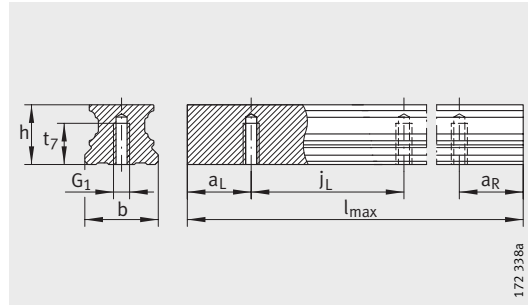

TKVD...U

172 338a

**Dimension table** · Dimensions in mm

Designation	Dimensions				Mounting dimensions								
	$l_{\max}^{1)}$	H	B	L	$A_1$	$J_B$	b	$A_2$	$L_1$	$J_L$	$j_L$	$a_L/a_R^{2)}$	
												min.	max.
<b>KUVE25-B-HS-H</b>	2960	40	48	89,3	12,5	35	23	6,5	60,7	35	60	20	53
<b>KUVE25-B-HS-S</b>	2960	36	48	89,3	12,5	35	23	6,5	60,7	35	60	20	53
<b>KUVE25-B-HS-SN</b>	2960	31	48	89,3	12,5	35	23	6,5	60,7	35	60	20	53

- 1) Maximum length of single piece guideways.  
Permissible guideway length by agreement. Max. single piece guideway length of 6 m by agreement.
- 2)  $a_L$  and  $a_R$  are dependent on the guideway length.
- 3) If there is a possibility of preload loss due to settling, the fixing screws should be secured against rotation.
- 4) Lubrication nipple with tapered head to DIN 71412-B M6 supplied loose.

**Dimension table (continued)** · Dimensions in mm

Designation	Carriage		Guideway			Load carrying capacity <sup>1)</sup>				
	Designation	Mass m ≈ kg	Designation	Mass m ≈ kg	Closing plug $K_2$	Basic load ratings		Moment ratings		
						dyn. $C_0$ N	stat. $C_0$ N	$M_{0x}$ Nm	$M_{0y}$ Nm	$M_{0z}$ Nm
<b>KUVE25-B-HS-H</b>	KWVE25-B-HS-H	0,65	TKVD25(-U)	2,7	KA11-TN/A	17 900	37 000	510	395	395
<b>KUVE25-B-HS-S</b>	KWVE25-B-HS-S	0,56	TKVD25(-U)	2,7	KA11-TN/A	17 900	37 000	510	395	395
<b>KUVE25-B-HS-SN</b>	KWVE25-B-HS-SN	0,45	TKVD25(-U)	2,7	KA11-TN/A	17 900	37 000	510	395	395

- 1) Calculation of basic load rating according to DIN 636.  
Increased basic dynamic load rating possible on the basis of practical experience.

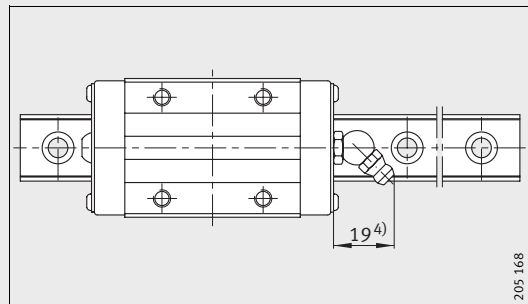

KUVE25-B-HS..

205.168

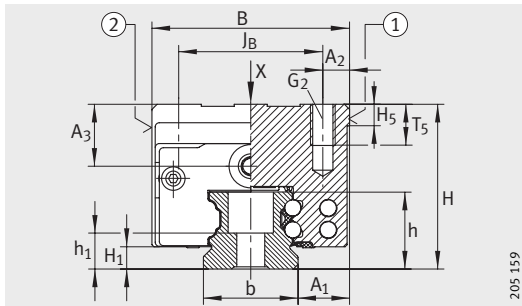

KUVE25-B-HS-H (-HS-S, -HS-SN)  
 ① Locating face, ② Marking

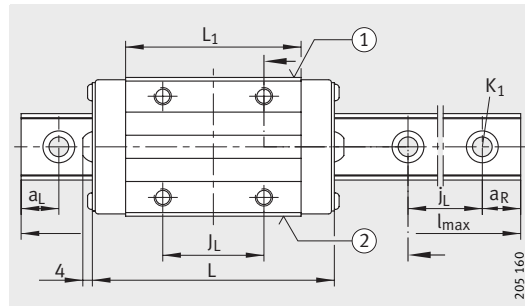

KUVE25-B-HS-H (-HS-S, -HS-SN) ·  
 View X (rotated 90°)  
 ① Locating face, ② Marking

H <sub>1</sub>	H <sub>5</sub>	A <sub>3</sub>	T <sub>5</sub>	t <sub>7</sub>	h	h <sub>1</sub>	Fixing screws <sup>3)</sup>					
							G <sub>1</sub>		G <sub>2</sub>		K <sub>1</sub>	
							DIN ISO 4 762-12.9					
5,1	5	15	10	12	18,7	8,7	M6	17	M6	10	M6	17
5,1	5	11	10	12	18,7	8,7	M6	17	M6	10	M6	17
5,1	5	6	7,5	12	18,7	8,7	M6	17	M6	10	M6	17

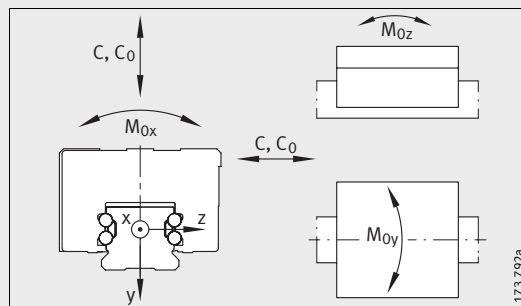

# Guideway for profiled sections

TKVD...-K

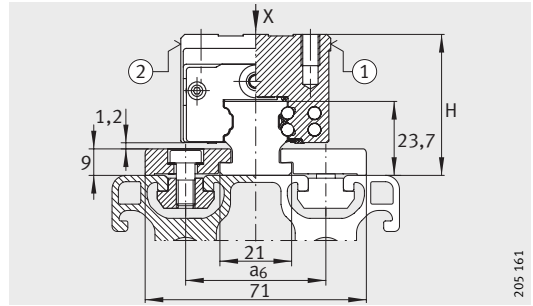

TKVD25-K with SPPR and SPPL · View X (rotated 90°)  
 ① Locating face, ② Marking

205 161

Dimension table · Dimensions in mm		
Guideway		Mounting dimension
Designation	Mass m ≈ kg/m	a <sub>6</sub>
<b>TKVD25-K</b>	3,2	40/45/50

1) Recommended distance between screws.  
 2) Maximum length of guideway and clamping strip;  
 longer guideways are supplied in several sections and are marked accordingly.  
 3) Caution!  
 The basic dynamic load rating C (page 6 and page 8) is only used for calculating the basic rating life.  
 The permissible load is dependent on the profile and the type and quantity of fasteners.

Dimension table · Dimensions in mm		
System height		
Carriage	Guideway	Dimensions H
<b>KWVE25-B-HS</b>	TKVD25-K	41
<b>KWVE25-B-HS-N</b>	TKVD25-K	36
<b>KWVE25-B-HS-H</b>	TKVD25-K	45
<b>KWVE25-B-HS-S</b>	TKVD25-K	41
<b>KWVE25-B-HS-SN</b>	TKVD25-K	36

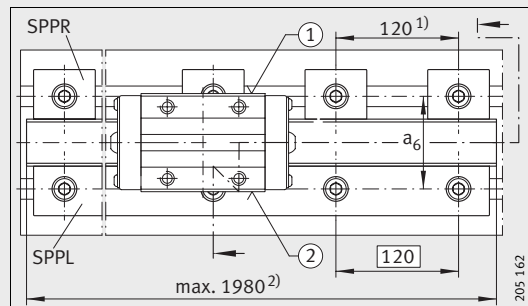

KUVE25-B-HS...-K with SPPR and SPPL  
 ① Locating face, ② Marking

205 162

# Clamping lug Clamping strip

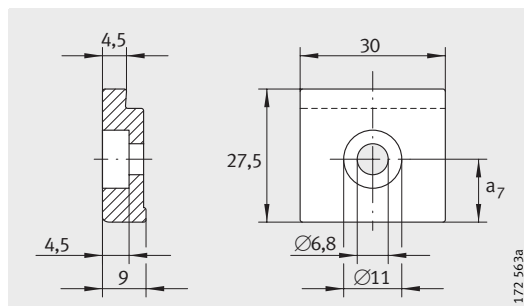

Clamping lug SPPR

## Dimension table - Dimensions in mm

Clamping lug		Clamping strip		Mounting dimension
Designation	Mass m ≈g	Designation	Mass m ≈kg/m	a <sub>7</sub>
<b>SPPR2540</b>	0,02	<b>SPPL2540</b>	0,6	15,5
<b>SPPR2545</b>	0,02	<b>SPPL2545</b>	0,6	13
<b>SPPR2550</b>	0,02	<b>SPPL2550</b>	0,6	10,5

<sup>1)</sup> a<sub>L</sub> and a<sub>R</sub> are dependent on the length of the strip.

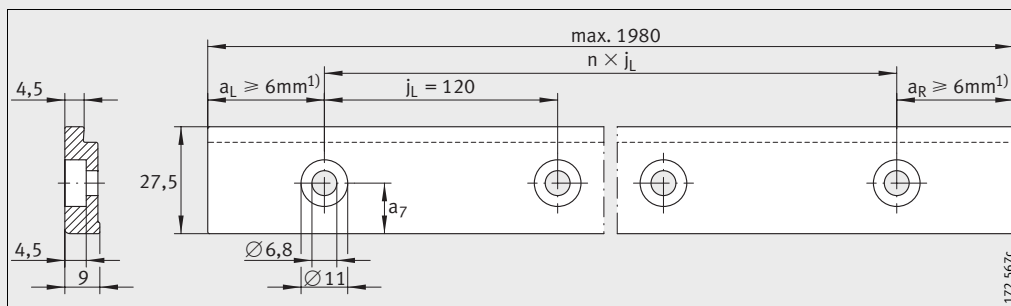

Clamping strip SPPL

**Schaeffler KG**

Linear Technology Division  
Berliner Strasse 134  
66424 Homburg/Saar (Germany)  
Internet [www.ina.com](http://www.ina.com)  
E-Mail [info.linear@schaeffler.com](mailto:info.linear@schaeffler.com)

In Germany:

Phone 0180 5003872

Fax 0180 5003873

From Other Countries:

Phone +49 6841 701-0

Fax +49 6841 701-2625

Every care has been taken to ensure the correctness of the information contained in this publication but no liability can be accepted for any errors or omissions.

We reserve the right to make technical changes.

© Schaeffler KG · 2007, June

This publication or parts thereof may not be reproduced without our permission.

TPI 145 GB-D